

# METROLOGY ESSENTIALS

AUSTRALIA & NEW ZEALAND

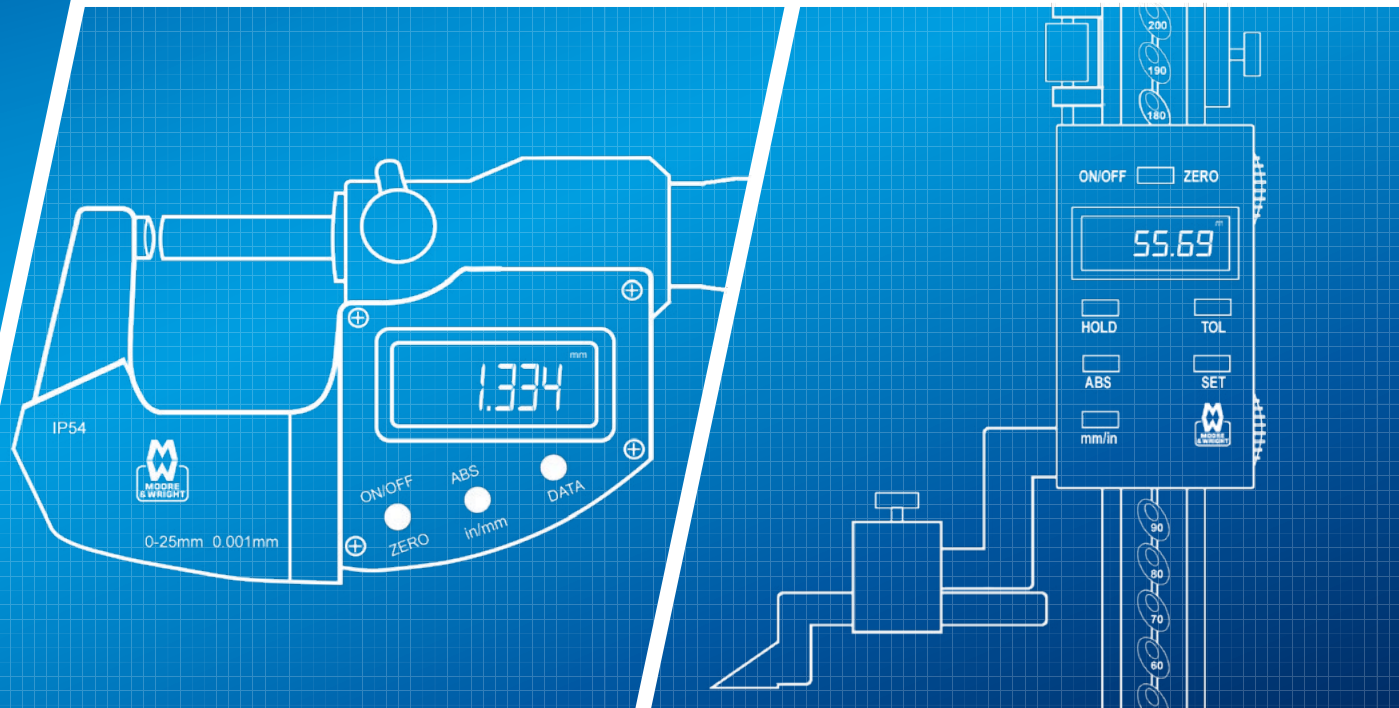

# Moore & Wright

## A Brief History

Founded in 1906 by innovative young engineer, Frank Moore, Moore & Wright has been designing, manufacturing and supplying precision measuring equipment to global industry for over 100 years. With roots fixed firmly in Sheffield, England, the company began by manufacturing a range of calipers, screwdrivers, punches and other engineer's tools. Following investment from Mrs Wright, a shrewd Sheffield businesswoman, Frank was able to expand the business and further develop his innovative designs.

By the mid-nineteen twenties, thanks to the company's enviable reputation, Moore & Wright was approached by the UK Government to consider manufacturing a range of quality micrometers. It was in this field that Moore & Wright's status as UK agent for the Swiss Avia range of products and subsequent acquisition of the Avia brand and manufacturing rights, proved invaluable. A set of working drawings was obtained from Switzerland and reworked based on popular American designs, whilst incorporating Moore & Wright's own innovations. The ensuing range of high quality instruments resulted in world renown for Moore & Wright micrometers. These early, classic designs are regarded as the origin of today's comprehensive range of micrometers, now used in every industrialised country throughout the world.



2

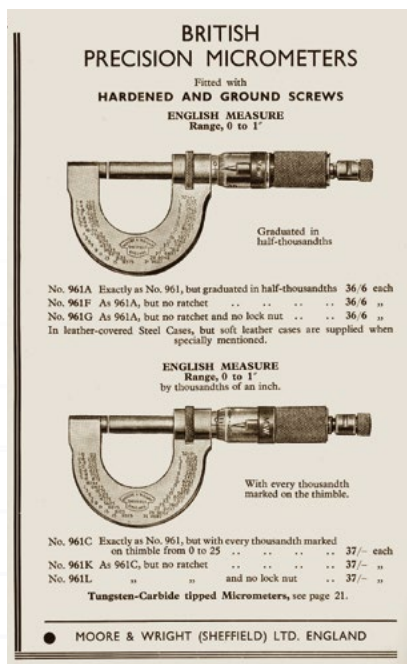

During World War Two, the overwhelming demand for Moore & Wright micrometers resulted in the opening of two further factories in England with production levels reaching an incredible 20,000 micrometers per month.

By the end of World War Two, control of the company had passed to Frank Moore's daughter who subsequently sold the business to John Shaw Company in 1945. John Shaw recognised the skill and business acumen of the Moore & Wright staff granting them a level of autonomy. This allowed them to continue to develop innovative new products that could be marketed in both the UK and overseas. Soon the company was producing a diverse range of precision tools, including small hole gauges, telescopic gauges and a wide range of vernier calipers.

By the early 1950s Moore & Wright's vastly expanded product portfolio and increased levels of production, meant that it had outgrown its current production sites. The answer to the company's manufacturing bottlenecks was to be found in a new state-of-the-art production facility in Sheffield.

In 1970, Moore & Wright was acquired by Neill Tools Group, when the John Shaw Company was purchased by Neill Tools. The years that followed saw an increased threat to company sales from products exported to the UK from overseas manufacturers. Helped by the purchase of well-known micrometer manufacturer, Shardlow and the quality caliper producer Bensons, Neill Tools jealously defended Moore & Wright's business. The company also embarked on a progressive micrometer design and development programme. After adopting

the suggested manufacturing and product design improvements, Moore & Wright launched Micro 2000, the world's first hand-held electronic micrometer. The company was proud to be awarded the coveted Queens Award For Technological Achievement in 1977 for this groundbreaking new product.

Now part of Bowers Group and with production facilities in the UK and China, Moore & Wright continues its commitment to supplying worldwide industry with high quality, affordable products. Its ongoing pledge to research and development should ensure that this great British company remains at the forefront of global innovation.

<b>CALIPERS</b>	<b>4</b>
<b>DEPTH GAUGES</b>	<b>22</b>
<b>HEIGHT GAUGES</b>	<b>26</b>
<b>MICROMETERS</b>	<b>29</b>
<b>BORE GAUGES</b>	<b>52</b>
<b>INDICATORS</b>	<b>54</b>
<b>INDICATOR STANDS</b>	<b>62</b>
<b>HAND TOOLS</b>	<b>69</b>
<b>LEVELLING</b>	<b>93</b>
<b>WORKSHOP TOOLS</b>	<b>99</b>



# Workshop Vernier Caliper 100 Series

## At a Glance

- Standard DIN 862
- Standard workshop model with locking screw
- 4-way measurement



Max Range:  
0-300mm (0-12")

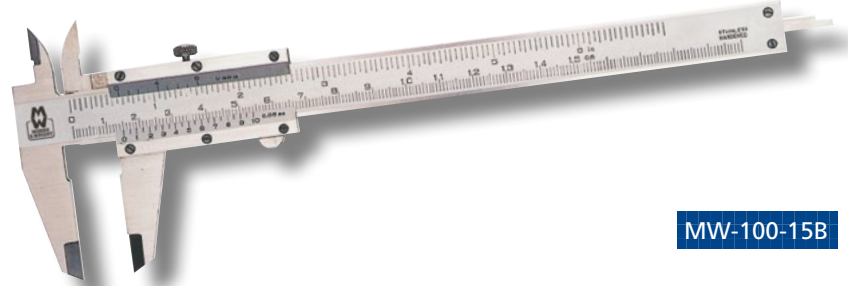



MW-100-15B

## Features

- Made of hardened stainless steel
- Chromed scale with laser engraved graduations
- Measuring surface is micro-lapped
- Supplied in case

4

## Workshop Vernier - 100 Series

Code No	Range (mm)	Range (inch)	Resolution (mm)	Accuracy (mm)	A (mm)	B (mm)	
MW-100-15B	0-150	0-6	0.05	1/128	0.05	40	16
MW-100-20B	0-200	0-8	0.05	1/128	0.05	50	20
MW-100-30B	0-300	0-12	0.05	1/128	0.08	55	20
MW-100-15BI	 0-150	0-6	0.02	0.001	0.02	40	16
MW-100-20BI	 0-200	0-8	0.02	0.001	0.03	50	20
MW-100-30BI	 0-300	0-12	0.02	0.001	0.04	55	20

## Availability & Compliance

- Available in Australia & New Zealand
-  Indent Only, not stocked, supplied to order



# Workshop Vernier Caliper 105 Series

## At a Glance

- Standard DIN 862
- Standard workshop model with locking screw
- 4-way measurement



Max Range:  
0-300mm (0-12")



MW-105-20

## Features

- With fine adjustment
- Made of hardened stainless steel
- Chromed scale with laser engraved graduations
- Measuring surface is micro-lapped
- Supplied in case

### Workshop Vernier - 105 Series

Code No	Range (mm)	Range (inch)	Resolution (mm)	Resolution (inch)	Jaws (mm)
MW-105-20	0-200	0-8	0.05	0.05	50
MW-105-30	0-300	0-12	0.05	0.05	55
MW-105-20I	0-200	0-8	0.02	0.02	50
MW-105-30I	0-300	0-12	0.02	0.02	55

## Availability & Compliance

- Available in Australia & New Zealand

# Precision Vernier Caliper

## 110 Series

### At a Glance

- Standard DIN 862
- Extra small precision vernier caliper
- 4-way measurement



Max Range:  
0-300mm (0-12")



MW-110-15

### Features

- Mono block
- Made of hardened stainless steel
- Chromed scale with laser engraved graduations
- Scale shows both mm and inch value
- Measuring surface is micro-lapped

### Precision Vernier - 110 Series

Code No	Range (mm)	(inch)	Resolution (mm)	(inch)	Jaws (mm)
MW-110-15	0-150	0-6"	0.05	1/128"	40
MW-110-20	0-200	0-8"	0.05	1/128"	40
MW-110-30	0-300	0-12"	0.05	1/128"	55
MW-110-15I	0-150	0-6"	0.02	0.001"	40
MW-110-20I	0-200	0-8"	0.02	0.001"	40
MW-110-30I	0-300	0-12"	0.02	0.001"	55

### Availability & Compliance

- Available in Australia & New Zealand

# Thumb Lock Vernier Caliper 115 Series

**CALIPERS**

## At a Glance

- Standard DIN 862
- Precision vernier caliper
- 4-way measurement



Max Range:  
0-150mm (0-6")



MW-115-15

## Features

- Mono block
- Made of hardened stainless steel
- Chromed scale with laser engraved graduations
- The scale shows both mm and inch value
- Measuring surface is micro-lapped

### Thumb Lock Vernier - 115 Series

Code No	Range (mm)	Range (inch)	Resolution (mm)	Resolution (inch)	Jaws (mm)
MW-115-15I	0-150	0-6	0.02	0.001	40mm
MW-115-20I	0-200	0-68	0.02	0.001	40mm

7

## Availability & Compliance

- Available in Australia & New Zealand

# Large Workshop Vernier Caliper 150 Series

## At a Glance

- Standard workshop model with locking screw
- Jaws for internal and external measurement



Max Range:  
0-1500mm (0-60")

## Features

- Made of hardened alloyed stainless steel
- Chromed scale with laser engraved graduations
- Measuring surface is micro-lapped
- With fine adjustment
- Supplied in wooden box

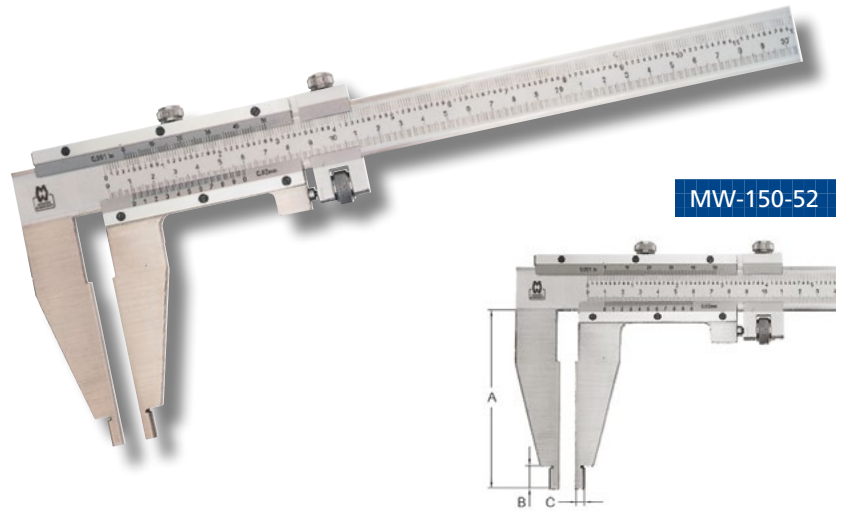

## Large Workshop Vernier - 150 Series

Code No	Range		Resolution		Accuracy	A	B	C
	(mm)	(inch)	(mm)	(inch)	(mm)	(mm)	(mm)	(mm)
MW-150-52	0-500	0-20	0.02	0.001	0.05	100	12	5
MW-150-62	0-600	0-24	0.02	0.001	0.05	100	12	5
MW-150-72	0-1000	0-40	0.02	0.001	0.07	125	18	10
MW-150-82	0-1500	0-60	0.02	0.001	0.11	150	18	10

## Availability & Compliance

- Available in Australia & New Zealand
- Indent Only, not stocked, supplied to order



# Mono Block Large Workshop Vernier Caliper 152 Series

## At a Glance

- Standard workshop model with locking screw
- Jaws for internal and external measurement



Max Range:  
0-1000mm

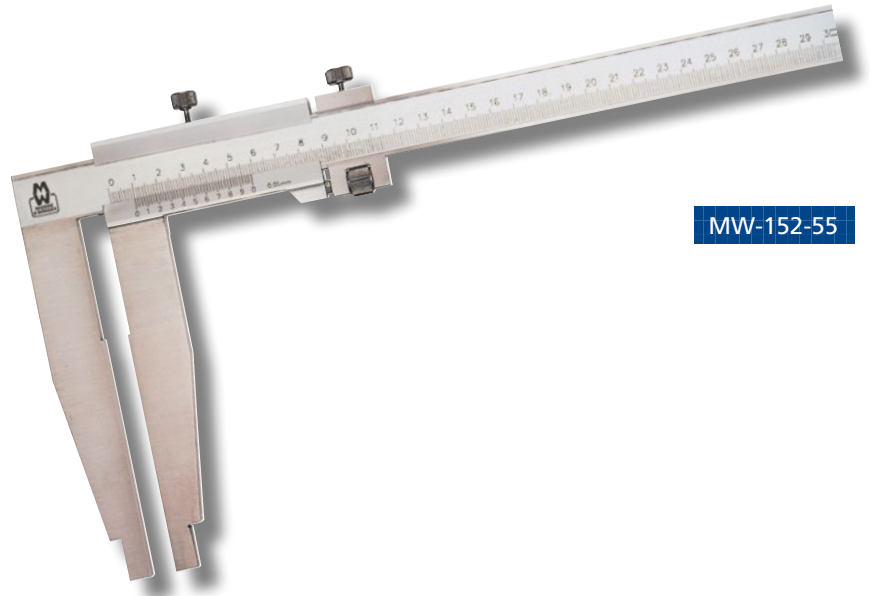

MW-152-55

## Features

- Mono block solid slider
- Made of hardened alloyed stainless steel
- Chromed scale with laser engraved metric graduations
- Measuring surface is micro-lapped
- With fine adjustment
- Packed in wooden box

### Mono Block Large Workshop Vernier - 152 Series

Code No		Range (mm)	Resolution (mm)	Jaws
MW-152-55		0-500	0.05	100mm
MW-152-65		0-600	0.05	100mm
MW-152-75		0-1000	0.05	125mm

## Availability & Compliance

- Available in Australia & New Zealand
- Indent Only, not stocked, supplied to order

# Long Jaw Vernier Caliper 155 Series

## At a Glance

- With longer jaws which permit the measurement of large workpieces
- Jaws for internal and external measurement



Max Range:  
0-1000mm (0-40")

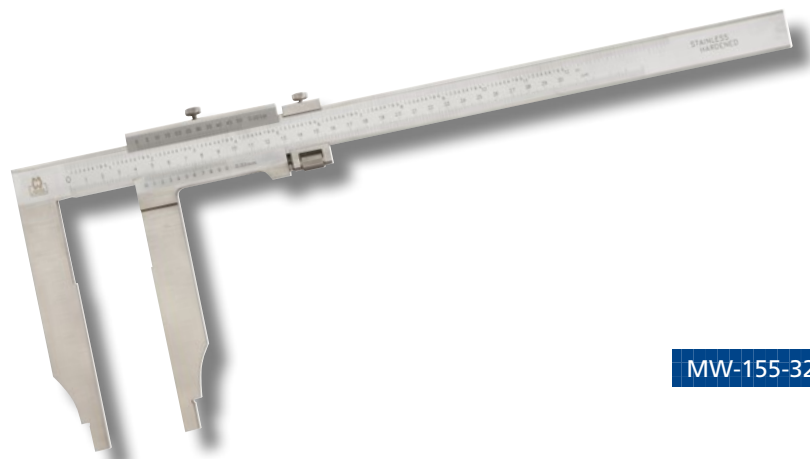

MW-155-32

## Features

- Locking screw for locking the slider
- Made of hardened stainless steel
- Chromed scale with engraved graduations
- Measuring surface is micro-lapped
- With fine adjustment
- Locking screw
- Supplied in wooden box

## Long Jaw Vernier - 155 Series

Code No	Range (mm)	(inch)	Resolution (mm)	(inch)	Jaws (mm)
MW-155-32	0-300	0-12	0.02	0.001	150
MW-155-52	0-500	0-20	0.02	0.001	200
MW-155-62	0-600	0-24	0.02	0.001	300
MW-155-72	 0-1000	0-40	0.02	0.001	300

## Availability & Compliance

- Available in Australia & New Zealand
-  Indent Only, not stocked, supplied to order

# Dial Caliper 146 Series

## At a Glance

- Adjustable dial for easy zero setting
- Shockproof



Max Range:  
0-300mm

## Features

- Made of Stainless Steel
- Extra smooth operation
- Blue anodized bezel
- Covered Rack
- Measuring surface is micro-lapped
- Thumb wheel for fine adjustment
- Supplied in case

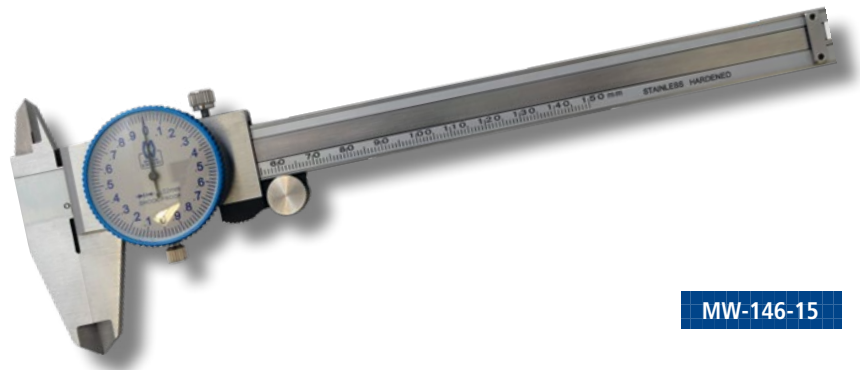

MW-146-15

### Dial - 140 Series - Metric

Code No	Range (mm)	Resolution (mm)	Accuracy (mm)
MW-146-15	0-150	0.02	0.02
MW-146-20	0-200	0.02	0.02
MW-146-30	0-300	0.02	0.03

### Dial Caliper - 140 Series - Imperial

Code No	Range (inch)	Resolution (inch)	Accuracy (inch)
MW-146-15I	 0-6	0.001	0.001

## Availability & Compliance

- Available in Australia & New Zealand
-  Indent Only, not stocked, supplied to order



# Workshop Digital Caliper 110-DBL Series

## At a Glance

- Standard: DIN 862
- 4-way measurement



Max Range:  
0-300mm (0-12")

## Features

- Functions: mm/inch conversion, on/off, zero-setting, ABS/INC, Auto off
- All metal parts made of hardened stainless steel
- Thumb wheel for fine adjustment
- CR2032 Battery
- Supplied in case



MW-110-15DBL

## Workshop Digital - 110-DBL Series

Code No	Range (mm)	(inch)	Resolution (mm)	(inch)	Accuracy (mm)	Jaws
MW-110-15DBL	0-150	0-6	0.01	0.0005	0.03	40mm
MW-110-20DBL	0-200	0-8	0.01	0.0005	0.03	50mm
MW-110-30DBL	0-300	0-12	0.01	0.0005	0.04	60mm



## Availability & Compliance

- Available in Australia & New Zealand
- Compliant with Australian Button Battery Standards

# Fractional Digital Caliper 110-DFC Series

## At a Glance

- Extra large, easy-to-read LCD display
- High measuring speed: 120" per second



Max Range:  
0-300mm (0-12")

## Features

- 4-way measurement
- Functions: mm / inch / fraction conversion, on / off, zero-setting
- Reading options: Metric / Inch / Fraction
- Stainless steel frame with extra smooth movements
- Thumb wheel for fine adjustment
- CR2032 Battery
- Supplied in case



MW-110-15DFC

## Fractional Reading Digital - 110-DFC Series

Code No	Range (mm)	(inch)	Resolution (mm)	(inch)	Accuracy (mm)	Jaws (mm)
MW-110-15DFC	0-150	0-6	0.01	0.0005	0.03	40
MW-110-20DFC	0-200	0-8	0.01	0.0005	0.03	50
MW-110-30DFC	0-300	0-12	0.01	0.0005	0.04	60

## Availability & Compliance

- Available in Australia & New Zealand
- Compliant with Australian Button Battery Standards

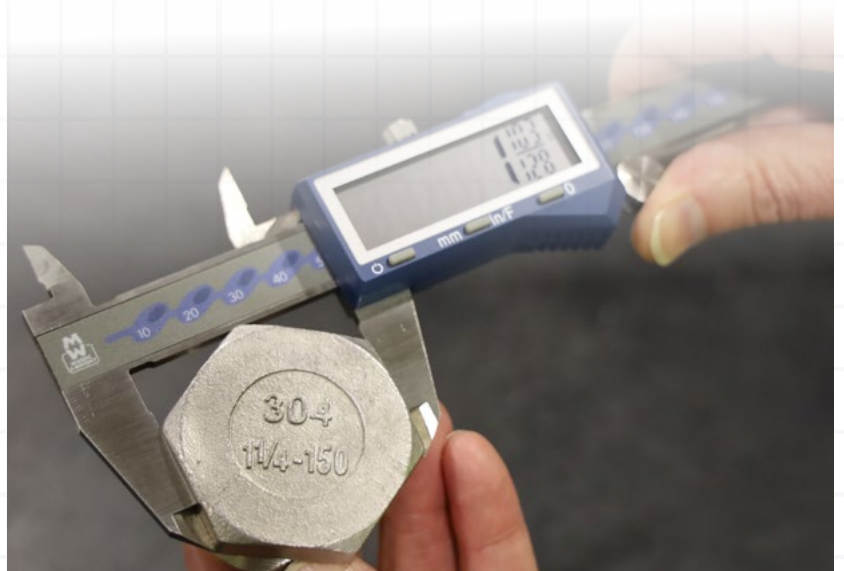

# Digital Absolute Caliper

## 110-DABS Series

### At a Glance

- Absolute Measuring System
- 4-way measurement



Max Range:  
0-300mm (0-12")



MW-110-15DABS

### Features

- Functions: mm/Inch conversion, on/off, data-output, 0...ABS
- USB data output
- Thumb wheel for fine adjustment
- CR2032 Battery
- Supplied in case

### Digital Absolute - 110-DABS Series

Code No	Range		Resolution		Accuracy	
	(mm)	(inch)	(mm)	(inch)	(mm)	(inch)
MW-110-15DABS	0-150	0-6	0.02	0.0005	0.01	0.02
MW-110-20DABS	0-200	0-8	0.03	0.0005	0.01	0.03
MW-110-30DABS	0-300	0-12	0.03	0.0005	0.01	0.03

### Data Cable

Code No	Description
MW-Y100/700USB	Data Cable-USB to suit all DABS products

### Availability & Compliance

- Available New Zealand Only
- Not Compliant with Australian Button Battery Standards

# IP54 Water Resistant Caliper 110-WR Series

## At a Glance

- Standard DIN 862
- 4-way measurement



Max Range:  
0-300mm (0-12")



**MW-110-15WR**

## Features

- Functions: mm/inch conversion, on/off, zero setting, ABS/INC
- Patented ceramic capacitive sensor
- IP54 Protection (dust protected and water resistant)
- Thumb wheel for fine adjustment
- CR2032 Battery
- Supplied in case

### IP54 Water Resistant 110-WR Series

Code No	Range (mm)	(inch)	Resolution (mm)	(inch)	Accuracy (mm)	Jaws (mm)
MW-110-15WR	0-150	0-6	0.01	0.0005	0.03	40
MW-110-20WR	0-200	0-8	0.01	0.0005	0.03	50
MW-110-30WR	0-300	0-12	0.01	0.0005	0.04	60

## Availability & Compliance

- Available in Australia & New Zealand
- Compliant with Australian Button Battery Standards



# Digital Vernier Caliper

## 110-WIP Series

### At a Glance

- 4-way measurement
- Extra large easy-to-read LCD display



Range:  
0-300mm (0-12")



MW-110-15WIP

### Features

- Inductive measurement system
- IP67 Protection (dust tight and immersion resistance up to 1m deep)
- SPC Data Output via bluetooth
- CR2032 Battery
- Supplied in case

### Digital Vernier - 110-WIP Series

Code No	Range (mm)	Range (inch)	Resolution (mm)	Resolution (inch)
MW-110-15WIP	0-150	0-6	0.01	0.05
MW-110-20WIP	0-200	0-8	0.01	0.05
MW-110-30WIP	0-300	0-12	0.01	0.02

### Availability & Compliance

- Available in Australia & New Zealand
- Compliant with Australian Button Battery Standards



# Digital Caliper Interchangeable Anvils

## At a Glance

- Interchangeable anvils for internal and external groove measurements



Max Range:  
0-300mm (0-12")

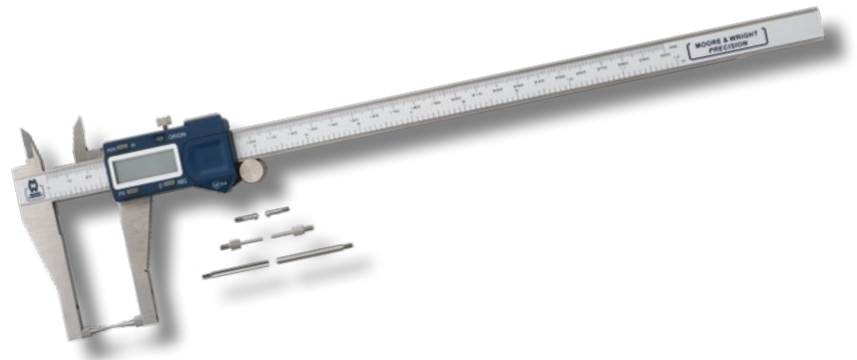

## Features

- Preset of measuring anvils required
- Glass Scale
- IP54 Protection (dust and water resistant)
- SPC Data Output via cable (optional)
- CR2032 Battery
- Anvil set included
- Anvils have M2.5 thread
- Supplied in case

### Digital - Interchangeable Anvils - 127-DABS Series

Code No	Range		Resolution		Accuracy	
	(mm)	(inch)	(mm)	(inch)	(mm)	(inch)
MW-127-30DABS	0-300	0-12	0.01	0.0005	0.04	0.0015

## Availability & Compliance

- Available in New Zealand Only
- Indent Only, not stocked, supplied to order
- Not Compliant with Australian Button Battery Standards

# Digital External Groove IP54 Caliper

## 120-DABS Series

### At a Glance

- Jaws for measuring external grooves, undercuts etc



Max Range:  
0-200mm (0-8")



### Features

- Functions: mm / inch conversion, on/off, zero-setting, ABS / zero
- SPC Data Output via cable (optional)
- Glass scale
- IP54 Protection (dust protected and water resistant)
- Thumb wheel for fine adjustment
- Locking Screw
- mm-inch conversion
- Absolute or incremental measurements
- Zero setting at any point
- CR2032 Battery
- Supplied in case

### Digital External Groove IP54 - 120-DABS Series

Code No	Range		Resolution		Accuracy	
	(mm)	(inch)	(mm)	(inch)	(mm)	(inch)
MW-120-20DABS	0-200	0-8	0.01	0.0005	0.03	0.0015



### Availability & Compliance

- Available in New Zealand Only
- Indent Only, not stocked, supplied to order
- Not Compliant with Australian Button Battery Standards

# Digital Long Jaw Caliper

## 110-DLJ Series

### At a Glance

- Heavy duty design
- Long jaws with internal measuring nib



Max Range:  
0-150mm (0-6")



### Features

- Functions: mm / inch conversion, on/off, zero-setting, ABS / zero, Battery low indication
- Measuring surface is micro-lapped
- Thumb wheel for fine adjustment
- LR44/A76 Battery
- Supplied in case

### Digital Long Jaw - 110-DLJ Series

Code No	Range		Resolution		Accuracy (mm)	Jaws (mm)	Internal Nibs (mm)
	(mm)	(inch)	(mm)	(inch)			
MW-110-15DLJ 	0-150	0-6	0.01	0.0005	0.03	60	10 x 5

### Availability & Compliance

- Available in New Zealand Only
-  Indent Only, not stocked, supplied to order
- Not Compliant with Australian Button Battery Standards

# Large Digital Workshop Caliper

## 150-DDL Series

### At a Glance

- Long jaws with internal measuring nib



Max Range:  
0-1000mm (0-40")

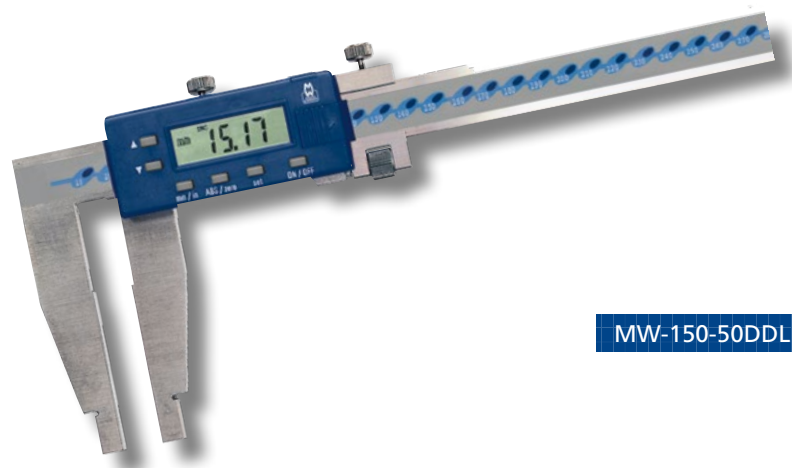

MW-150-50DDL

### Features

- Functions: mm / inch conversion, on/off, data-output, zero-setting, ABS / zero, Battery low indication
- Measuring surface is micro-lapped
- Thumb wheel for fine adjustment
- CR2032 Battery
- Supplied in Case

### Large Digital Workshop - 150 Series

Code No	Range		Resolution		Accuracy	Jaws	Internal Nibs
	(mm)	(inch)	(mm)	(inch)	(mm)	(mm)	(mm)
MW-150-50DDL	0-500	0-20	0.01	0.0005	0.05	100	18 x 10
MW-150-60DDL	0-600	0-24	0.01	0.0005	0.05	100	24 x 10
MW-150-75DDL	0-1000	0-40	0.01	0.0005	0.07	125	24 x 10

### Availability & Compliance

- Available in New Zealand Only
- **i** Indent Only, not stocked, supplied to order
- Not Compliant with Australian Button Battery Standards

# Heavy Duty Digital Workshop Caliper 160-D Series

**CALIPERS**

## At a Glance

- Heavy duty design
- Standard jaws with nibs for internal measuring, top knife jaws for external measuring



Max Range:  
0-300mm (0-12")

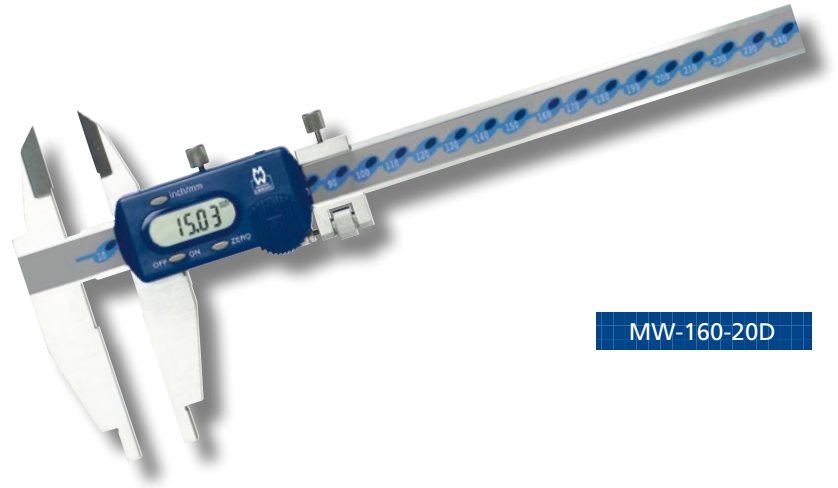

MW-160-20D

## Features

- Functions: mm / inch conversion, on/off, zero-setting, Battery low indication
- Measuring surface is micro-lapped
- Thumb wheel for fine adjustment
- LR44/A76 Battery
- Supplied in Case

## Heavy Duty Digital Workshop - 160-D Series

Code No	Range (mm) (inch)	Resolution (mm) (inch)	Accuracy (mm)	Jaws (mm)	External Knife Edge	Internal Nibs
MW-160-20D	0-200 0-8	0.01 0.0005	0.03	0.0005	12mm	33.5 x 5
MW-160-30D	0-300 0-12	0.01 0.0005	0.04	0.0005	12mm	38 x 5

21

## Availability & Compliance

- Available in New Zealand Only
- Indent Only, not stocked, supplied to order
- Not Compliant with Australian Button Battery Standards

# Vernier Depth Gauge 170 Series

## At a Glance

- Standard workshop model made of alloyed stainless steel



Max Range:  
0-500mm (0-20")

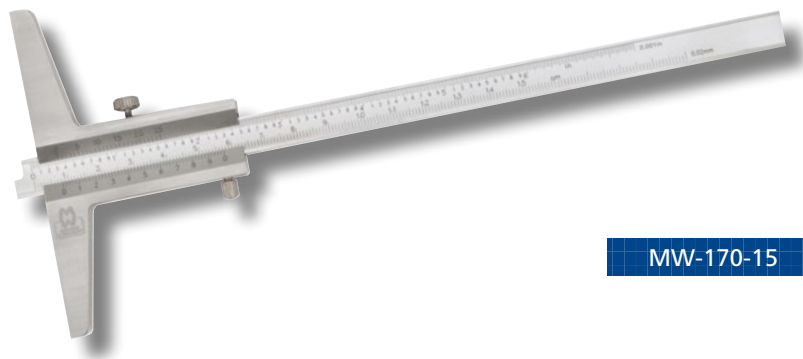

MW-170-15

## Features

- Mono block with locking screw
- With laser engraved graduations
- Measuring surface is micro-lapped
- Supplied in case

## Vernier - 170 Series

Code No	Range (mm)	Resolution (mm)	(inch)	Size of Base (mm)
MW-170-15	0-150	0.02	0.001	100
MW-170-20	0-200	0.02	0.001	100
MW-170-30	0-300	0.02	0.001	100
MW-170-50BI	0-500	0.02	0.001	150

## Availability & Compliance

- Available in Australia & New Zealand

# Digital Depth Gauge Caliper 170-DB Series

## At a Glance

- Standard workshop model made of alloyed stainless steel



Max Range:  
0-300mm (0-12")

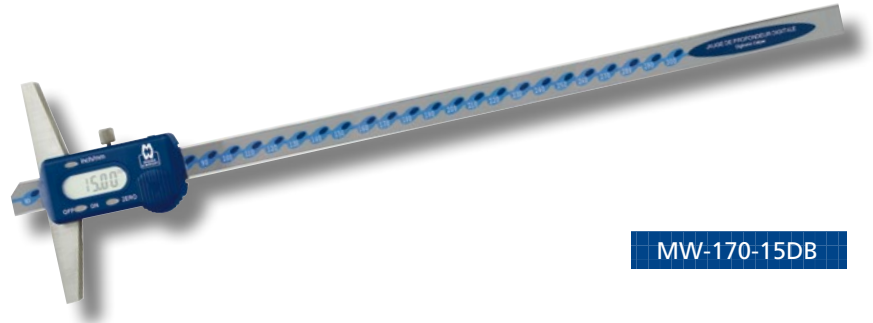

MW-170-15DB

## Features

- Functions: mm/inch conversion, on/off, zero setting, Battery low indication
- Measuring surface is micro-lapped
- LR44/A76 Battery
- Supplied in case

### Digital - Without Hook - 170-DB Series

Code No	Range (mm)	Range (inch)	Resolution (mm)	Resolution (inch)	Accuracy (mm)	Size of Base (mm)
MW-170-15DB	0-150	0-6	0.01	0.0005	0.03	100
MW-170-20DB	0-200	0-8	0.01	0.0005	0.03	100
MW-170-30DB	0-300	0-12	0.01	0.0005	0.04	150
MW-170-30DB/100	 0-300	0-12	0.01	0.0005	0.04	100

## Availability & Compliance

- Available in Australia & New Zealand
-  Indent Only, not stocked, supplied to order
- Compliant with Australian Button Battery Standards

# Dial Depth Gauge 172 Series

## At a Glance

- 0-25mm travel dial indicator
- Metric only



Max Range:  
0-550mm

## Features

- Satin chrome finish
- Rods connect together for full 550mm capacity
- Includes 2 extra points for small hole applications
- Base size: 100mm
- Supplied in case



## Dial - 172 Series

Code No	Range (mm)	Resolution (mm)	Accuracy (mm)
MW-172-01	0-550	0.01	0.05

## Availability & Compliance

- Available in Australia & New Zealand



# Digital Depth Gauge 172-D Series

## At a Glance

- 0-25mm / 0-1" travel indicator



Max Range:  
0-550mm (0-22")

## Features

- Functions: mm / inch conversion, on/off, zero-setting
- Rods connect together for full 550mm capacity
- Includes 2 extra points for small hole applications
- Base size: 100mm
- LR44/A76 Battery
- Supplied in case



### Digital - 172 Series

Code No	Range		Resolution		Accuracy (mm)
	(mm)	(inch)	(mm)	(inch)	
MW-172-01D	0-550	0-22	0.01	0.0005	0.05

## Availability & Compliance

- Available in New Zealand Only
- **i** Indent Only, not stocked, supplied to order
- Not Compliant with Australian Button Battery Standards

# Double Column Height Gauge 195 Series

## At a Glance

- Dual directional mechanical counters and dial indicator for fast, error free measurements
- Metric only



Max Range:  
0-600mm

## Features

- Double column combines high stability with absolute accuracy
- Provided with a hand feed wheel for easy up and down feeding
- Mechanical counters can be set to zero at any position
- With carbide tipped scriber
- Counter reads steps of 1mm
- Supplied in case



MW-195-30

### Double Column - 195 Series

Code No		Range (mm)	Resolution (mm)	Size of Base (mm)
MW-195-30		0-300	0.01	125 x 85
MW-195-50		0-600	0.01	180 x 120

## Availability & Compliance

- Available in Australia & New Zealand
- Indent Only, not stocked, supplied to order

# Digital Height Gauge 193 -DDL Series

## At a Glance

- Easy to read LCD Display



Max Range:  
0-600mm (0-24")

## Features

- Functions: mm/inch conversion, on/off, zero setting, Battery low indication
- Fine adjustment for high precision measurement
- Measuring surface is micro-lapped
- Hand wheel operation with positive lock
- Supplied with carbide tipped scriber
- LR44/A76 Battery
- Supplied in case



MW-193-30DDL

### Digital - 193 Series

Code No		Range (mm)	Resolution (mm)	Repeatability (mm)	Accuracy (inch)
MW-193-30DDL		0-300	0.01	0.01	0.040
MW-193-60DDL		0-600	0.01	0.01	0.050

## Availability & Compliance

- Available in New Zealand Only
- Indent Only, not stocked, supplied to order
- Not Compliant with Australian Button Battery Standards

# Double Column Digital Height Gauge

## 195- DDL Series

### At a Glance

- Large 7.5mm high, digital display



Max Range:  
0-600mm (0-24")

### Features

- Double column combines high stability with absolute accuracy
- Functions: mm/inch conversion, on/off, data-output, zero-setting, max, min, Battery low indication
- Provided with a hand feed wheel for easy up and down feeding
- Measuring surface is micro-lapped
- Carbide tipped scriber
- LR44/A76 Battery
- Suppleid in case



MW-195-30DDL

### Double Column Digital - 195 Series

Code No	Range		Resolution		Accuracy (mm)	Size of Base (mm)
	(mm)	(inch)	(mm)	(inch)		
MW-195-30DDL	0-300	0.01	0.01	0.0005	0.03	125 x 85
MW-195-60DDL	0-600	0.01	0.01	0.0005	0.06	180 x 120

### Availability & Compliance

- Available in New Zealand Only
- Indent Only, not stocked, supplied to order
- Not Compliant with Australian Button Battery Standards



# Traditional External Micrometer 1965 Series

## At a Glance

- Standard: BS870, DIN 863/1, ISO361
- Tungsten carbide measuring faces



Max Range:  
0-25mm (0-1")

## Features

- Blue textured tapered bow frame
- Speeder type ratchet
- Locking lever
- Adjusting key
- 6.5mm spindle diameter
- Supplied in case



1965M

## Traditional External - 1965 Series

Code No	Range (mm)	Resolution (mm)	Code No	Range (inch)	Resolution (inch)
MW-1965M	0-25	0.01	MW-1965	0-1	0.001

## Accuracy

Micrometer Range Max Size up to	Measuring Faces Flatness	Screw Pitch Parallelism	Accuracy
25mm	0.001mm	0.003mm	0.003mm
1"	0.00005"	0.0001"	0.0001"

## Availability & Compliance

- Available in Australia & New Zealand



# Traditional External Micrometers, 1966 Series

## At a Glance

- Complies with: BS870, DIN 863/1, ISO361
- Tungsten carbide measuring faces



Max Range:  
0-150mm (0-6")



1966M50

## Features

- Blue textured frame finish
- Speeder type ratchet
- Locking lever
- Adjusting key
- Choice of standard or vernier type sleeve
- Spindle diameter 6.5mm
- Supplied in case with setting standard

## Traditional External - 1966 Series

Code No	Range (mm)	Resolution (mm)	Code No	Range (inch)	Resolution (inch)
MW-1966M50	25-50	0.01	MW-19662	1-2	0.001
MW-1966M75	50-75	0.01	MW-19663	2-3	0.001
MW-1966M100	75-100	0.01	MW-19664	3-4	0.001
MW-1966M125	100-125	0.01	MW-19665	4-5	0.001
MW-1966M150	125-150	0.01	MW-19666	5-6	0.001
MW-1966MB50	25-50	0.005			
MW-1966MB75	50-75	0.005			
MW-1966MB100	75-100	0.005			
MW-1966MB125	100-125	0.005			
MW-1966MB150	125-150	0.005			

## Accuracy

Micrometer Range Max Size up to	Measuring Faces		Screw Pitch Accuracy
	Flatness	Parallelism	
50mm	0.001mm	0.003mm	0.003mm
2"	0.00005"	0.0001"	0.0001"
150mm	0.001mm	0.005mm	0.003mm
6"	0.00005"	0.0002"	0.0001"

## Availability & Compliance

- Available in Australia & New Zealand
- Indent Only, not stocked, supplied to order

# External Micrometer 200 Series

## At a Glance

- Standard: DIN 863/1



Max Range:  
0-100mm (0-4")

## Features

- Satin chrome scale  
Hammertone finish frame with insulated grip
- Tapered frame for easier access to difficult areas
- Tungsten carbide measuring faces
- Constant force ratchet on thimble
- Supplied in case with setting standard and adjusting key







MW-200-01

### External - 200 Series - Metric

Code No	Range (mm)	Resolution (mm)
MW-200-01	0-25	0.01
MW-200-02	25-50	0.01
MW-200-03	50-75	0.01
MW-200-04	75-100	0.01

31

### External - 200 Series - Imperial

Code No	Range (inch)	Resolution (inch)
MW-200-01I	 0-1	0.0005
MW-200-02I	 1-2	0.0005
MW-200-03I	 2-3	0.0005
MW-200-04I	 3-4	0.0005

## Availability & Compliance

- Available in Australia & New Zealand
-  Indent Only, not stocked, supplied to order

# Workshop Outside Micrometer 200-BL Series

## At a Glance

- Standard: DIN 863
- Metric only



Max Range:  
0-100mm

## Features

- Standard workshop model
- Satin-chrome scale
- Painted frame
- Tapered frame for easier access to difficult areas
- Tungsten carbide measuring face
- Constant force ratchet
- Supplied in case with setting standard and adjusting key

## Availability & Compliance

- Available in Australia & New Zealand



MW-200-01BL

## Workshop Outside - 200-BL Series

Code No	Range (mm)	Resolution (mm)
MW-200-01BL	0-25	0.01
MW-200-02BL	25-50	0.01
MW-200-03BL	50-75	0.01
MW-200-04BL	75-100	0.01



# Workshop External Micrometer Set 215 Series

## At a Glance

- Standard: DIN 863



Max Range:  
0-200mm (0-8")



MW-215-01BL

## Features

- Tungsten carbide measuring faces
- Satin-chrome scale
- Satin-chrome forged steel frame with insulated grip
- Constant force ratchet on thimble
- Supplied in wooden box with setting standard and adjusting key

### Workshop External Set - 215 Series - Metric

Code No	Range (mm)	Resolution (mm)	Quantity
MW-215-01BL	0-75	0.01	3 Micrometers In Set
MW-215-02BL	0-100	0.01	4 Micrometers In Set
MW-215-03BL	0-150	0.01	6 Micrometers In Set
MW-215-04BL	0-200	0.01	8 Micrometers In Set

33

### Workshop External Micrometer Set - 215 Series - Imperial

Code No	Range (inch)	Resolution (inch)	Quantity
MW-215-01BI	0-3	0.001	3 Micrometers In Set
MW-215-02BI	0-4	0.001	4 Micrometers In Set
MW-215-03BI	0-6	0.001	6 Micrometers In Set
MW-215-04BI	0-8	0.001	8 Micrometers In Set

## Availability & Compliance

- Available in Australia & New Zealand
- Indent Only, not stocked, supplied to order

# Digital External Micrometer

## 201-DAB Series

### At a Glance

- Standard: DIN 863
- Large LCD display



Max Range:  
0-100mm (0-4")

### Features

- Functions: mm/inch conversion, ABS/INC, on/off, zero-setting
- Rugged steel design
- IP54 Protection (dust protected and water resistant)
- Tungsten carbide measuring faces
- Hammertone finished frame with high quality insulated grip
- Tapered for easier access to difficult areas
- Constant force ratchet on thimble
- Locking lever
- Ball attachment included
- LR44/A76 Battery
- Supplied in case with setting standard over 25mm



MW-201-01DAB

### Digital External - 201 Series

Code No	Range (mm)	(inch)	Resolution (mm)	(mm)
MW-201-01DAB	0-25	0-1	0.01	0.0005
MW-201-02DAB	25-50	1-2	0.01	0.0005
MW-201-03DAB	50-75	2-3	0.01	0.0005
MW-201-04DAB	75-100	3-4	0.01	0.0005

### Data Cable

Code No	Description
MW-Y100/700USB	Data Cable-USB to suit all DABS products

### Availability & Compliance

- Available in Australia & New Zealand
- Compliant with Australian Button Battery Standards

# Digital External Micrometer IP65 203-DABI Series

## At a Glance

- Standard: DIN 863/1
- Micron resolution



Max Range:  
0-300mm (0-12")



MW-203-01DABI

## Features

- Functions: mm/inch conversion, ABS/INC, on/off, zero-setting
- IP65 Protected (dust tight and water resistant)
- SPC data output via bluetooth adaptor
- Tungsten carbide measuring faces
- mm/inch conversion
- Large LCD display
- Ball attachment included
- LR44/A76 Battery
- Supplied in case with setting standard over 50mm

### Digital External IP65 - 203 Series

Code No	Range		Resolution	
	(mm)	(inch)	(mm)	(inch)
MW-203-01DABI	0-25	0-1	0.001	0.00005
MW-203-02DABI	25-50	1-2	0.001	0.00005
MW-203-03DABI	50-75	2-3	0.001	0.00005
MW-203-04DABI	75-100	3-5	0.001	0.00005
MW-203-05DABI	100-125	4-5	0.001	0.00005
MW-203-06DABI	125-150	5-6	0.001	0.00005
MW-203-07DABI	150-175	6-7	0.001	0.00005
MW-203-08DABI	175-200	7-8	0.001	0.00005
MW-203-09DABI	200-225	8-9	0.001	0.00005
MW-203-10DABI	225-250	9-10	0.001	0.00005
MW-203-11DABI	250-275	10-11	0.001	0.00005
MW-203-12DABI	275-300	11-12	0.001	0.00005
MW-203-SPC-BT	Bluetooth output adapter P1805			

## Availability & Compliance

- Available in Australia & New Zealand
- Indent Only, not stocked, supplied to order
- Compliant with Australian Button Battery Standards



# Large External Metric Micrometer 210 Series

## At a Glance

- Standard: DIN 863
- Metric Only



Max Range:  
0-300mm



MW-210-02

## Features

- Tungsten carbide measuring faces
- Satin-chrome scale
- Strong forged steel hammertone finish frame with insulated grip
- Constant force ratchet on thimble
- Supplied in wooden box with setting standard and adjusting key

## Large External - 210 Series

Code No	Range (mm)	Resolution (mm)
MW-210-01	100-125	0.01
MW-210-02	125-150	0.01
MW-210-03	150-175	0.01
MW-210-04	175-200	0.01
MW-210-05	200-225	0.01
MW-210-06	225-250	0.01
MW-210-07	250-275	0.01
MW-210-08	275-300	0.01

## Availability & Compliance

- Available in Australia & New Zealand

# Micrometer Interchangeable Anvils 217 Series

## At a Glance

- Standard: DIN 863
- Features wide measuring range with interchangeable anvils



Max Range:  
0-300mm (0-12")



MW-217-01

## Features

- Hardened and ground spindles/anvils
- Tungsten carbide measuring faces
- Satin-chrome scale
- Strong forged steel hammertone finish frame with insulated grip
- Constant force ratchet on thimble
- Supplied in wooden box with setting standard and adjusting key

### Interchangeable Anvils - 217 Series - Metric

Code No	Range (mm)	Resolution (mm)
MW-217-01	0-100	0.01
MW-217-02	0-150	0.01
MW-217-03	100-200	0.01
MW-217-04	150-300	0.01
MW-217-05	200-300	0.01

37

### Interchangeable Anvils - 217 Series - Imperial

Code No	Range (inch)	Resolution (inch)
MW-217-01I	0-4	0.001
MW-217-02I	0-6	0.001
MW-217-03I	4-8	0.001
MW-217-04I	6-12	0.001
MW-217-05I	8-12	0.001

## Availability & Compliance

- Available in Australia & New Zealand
- Indent Only, not stocked, supplied to order

# Large Adjustable External Metric Micrometer 220 Series

## At a Glance

- Standard: DIN 863
- Wide measuring range with interchangeable anvils
- Metric only



Max Range:  
0-1400mm

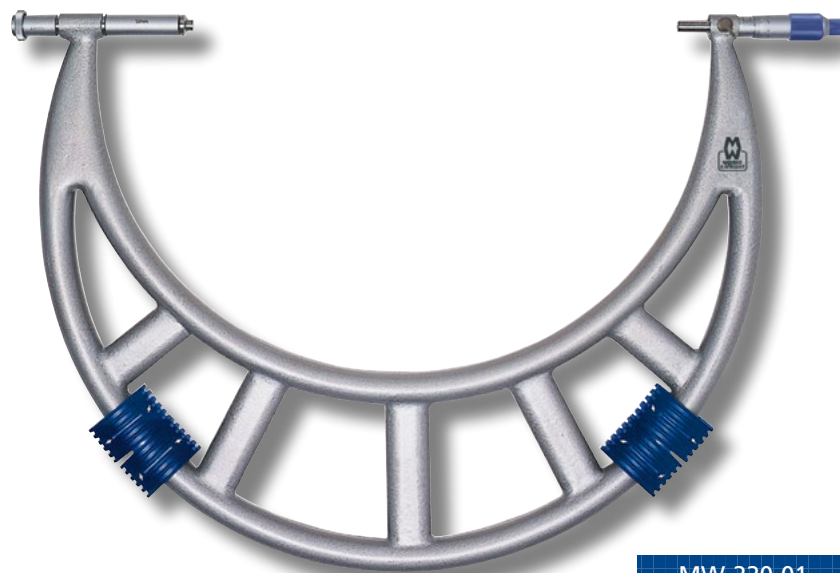

MW-220-01

## Features

- Low weight tubular frame with insulated grips
- Tungsten carbide measuring faces
- Hardened and ground spindles/anvils
- Satin-chrome scale
- Constant force ratchet on thimble
- Supplied in wooden box with setting standard and adjusting key

## Large Adjustable External - 220 Series

Code No	Range (mm)	Resolution (mm)
MW-220-01	300-400	0.01
MW-220-02	400-500	0.01
MW-220-03	500-600	0.01
MW-220-04	 600-700	0.01
MW-220-05	 700-800	0.01
MW-220-06	 800-900	0.01
MW-220-07	 900-1000	0.01
MW-220-08	 1000-1200	0.01
MW-220-09	 1200-1400	0.01

## Availability & Compliance

- Available in Australia & New Zealand
-  Indent Only, not stocked, supplied to order

# Large Adjustable External Digital Micrometer 220 Series

## At a Glance

- Standard: DIN 863
- Wide measuring range with interchangeable anvils
- Micron resolution



Max Range:  
0-1000mm (0-40")

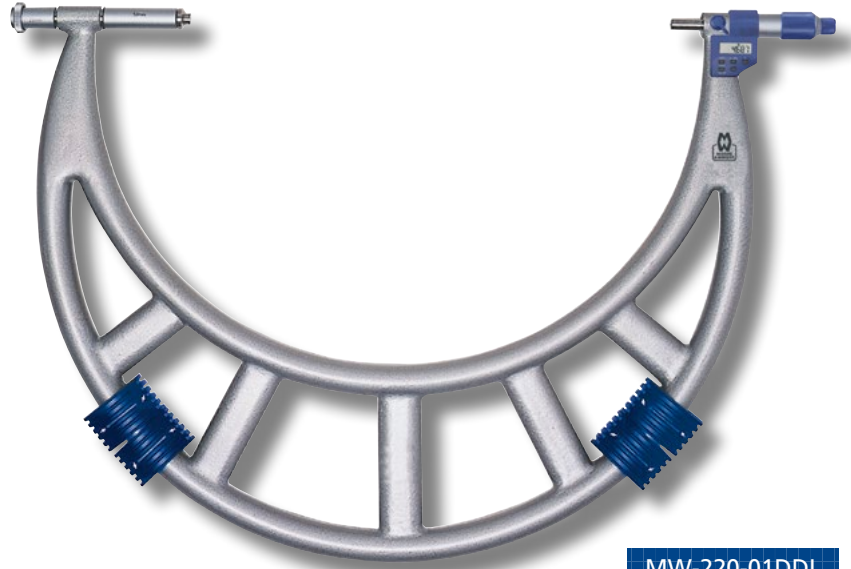

MW-220-01DDL

## Features

- Functions: mm/inch conversion, tolerance indication, on/off, zero-setting, Battery low indication
- Low weight tubular frame with insulated grips
- Tungsten carbide measuring faces
- Hardened and ground spindles/anvils
- Satin-chrome scale
- Constant force ratchet on thimble
- LR44/A76 Battery
- Supplied in wooden box with setting standard and adjusting key

## Large Adjustable External Digital - 220 Series

Code No		Range (mm)	Range (inch)	Resolution (mm)	Resolution (inch)
MW-220-01DDL		300-400	12-16	0.001	0.00005
MW-220-02DDL		400-500	16-20	0.001	0.00005
MW-220-03DDL		500-600	20-24	0.001	0.00005
MW-220-04DDL		600-700	24-28	0.001	0.00005
MW-220-05DDL		700-800	28-32	0.001	0.00005
MW-220-06DDL		800-900	32-36	0.001	0.00005
MW-220-07DDL		900-1000	36-40	0.001	0.00005

## Availability & Compliance

- Available in Australia & New Zealand
- Indent Only, not stocked, supplied to order
- Compliant with Australian Button Battery Standards

# Workshop Blade Micrometer 275 Series

## At a Glance

- Standard: DIN 863
- Measuring grooves, keyways etc.
- Metric only



Max Range:  
0-100mm





## Features

- Blade 6.5mm Not-rotating spindle
- Blade 1.25mm thick
- Satin chrome scale
- Hammertone finish frame with insulated grip
- Tapered for easier access to difficult areas
- Constant force ratchet on thimble
- Supplied in case with setting standard and adjusting key



MW-275-01

## Workshop Blade - 275 Series

Code No	Range (mm)	Resolution (mm)
MW-275-01	 0-25	0.01
MW-275-02	 25-50	0.01
MW-275-03	 50-75	0.01
MW-275-04	 75-100	0.01

## Availability & Compliance

- Available in Australia & New Zealand
-  Indent Only, not stocked, supplied to order



# Tube Micrometer 255 Series

## At a Glance

- Standard: DIN 863
- Spherical anvil for measuring tube wall thickness
- Metric only



Max Range:  
0-25mm

## Features

- Tungsten carbide measuring faces on spindle
- Satin chrome scale
- Hammertone finished frame with insulated grip
- Constant force ratchet on thimble
- Supplied in case



## Tube - 255 Series

Code No	Range (mm)	Resolution (mm)	Accuracy (mm)
MW-255-01	 0-25	0.01	0.006

## Dimensions

Code No	A (mm)	B (mm)
MW-255-01	4.75	27.5

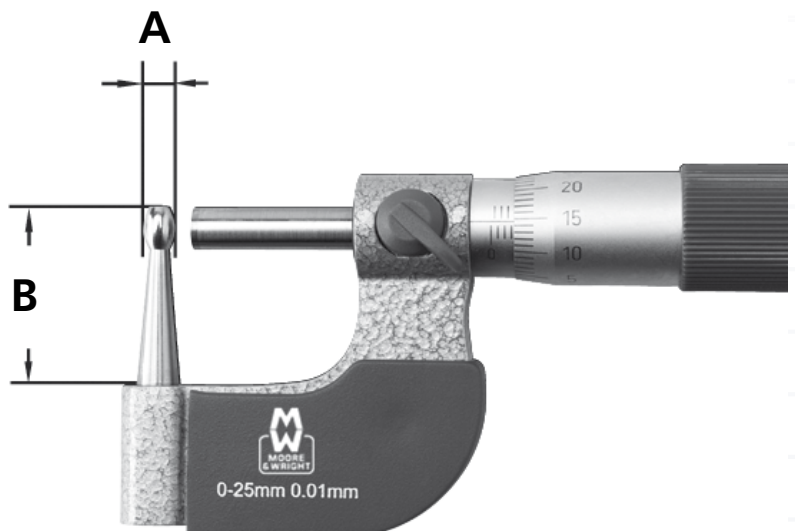

## Availability & Compliance

- Available in Australia & New Zealand
-  Indent Only, not stocked, supplied to order

# Digital Tube Micrometer 255-DDL Series

## At a Glance

- Standard: DIN 863
- Spherical anvil for measuring tube wall thickness



Max Range:  
0-25mm (0-1")



## Features

- Functions: mm/inch conversion, on/off, zero-setting, Battery low indication, hold, 0...ABS
- Tungsten carbide measuring faces on spindle
- IP54 Protection (dust protected and water resistant)
- Chrome plated frame with high quality insulated grip
- Constant force ratchet on thimble
- LR44/A76 Battery
- Supplied in case with Battery cover key

## Tube Digital - 255 Series

Code No	Range (mm)	Range (inch)	Resolution (mm)	Resolution (inch)	Accuracy (mm)
MW-255-01DDL	0-25	0-1	0.01	0.00005	0.003

## Dimensions

Code No	A (mm)	B (mm)
MW-255-01DDL	4.75	27.5

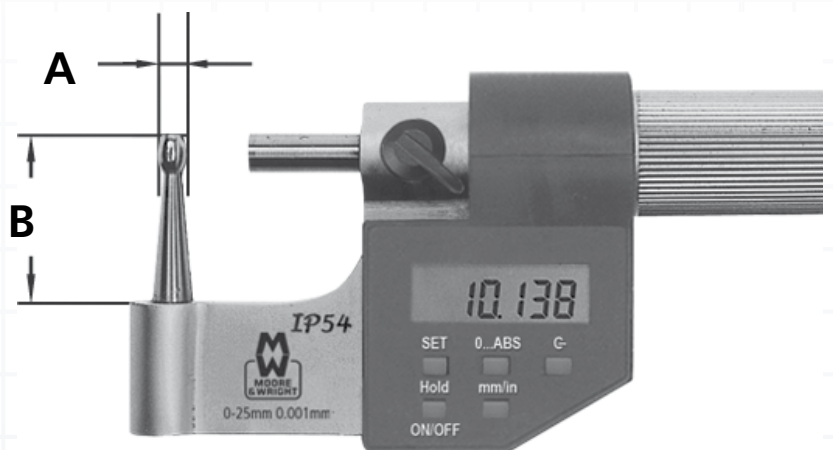

## Availability & Compliance

- Available in Australia & New Zealand
- Indent Only, not stocked, supplied to order
- Compliant with Australian Button Battery Standards



# Point Micrometer 270 Series

## At a Glance

- Standard: DIN 863
- Pointed spindle and anvil for measuring hard to reach places like the web thickness of drills, small grooves, keyways etc
- Metric only



Max Range:  
0-100mm



MW-270-01

## Features

- Tungsten carbide measuring faces
- Hammertone finished frame with high quality insulated grip
- Tapered for easier access to difficult areas
- Constant force ratchet on thimble
- Supplied in case with setting standard and adjusting key

## Point - 270 Series

Code No		Range (mm)	Resolution (mm)	Accuracy (mm)	Point Angle
MW-270-01		0-25	0.01	0.004	15°
MW-270-02		25-50	0.01	0.004	15°
MW-270-03		50-75	0.01	0.005	15°
MW-270-04		75-100	0.01	0.005	15°
MW-270-05		0-25	0.01	0.004	30°
MW-270-06		25-50	0.01	0.004	30°
MW-270-07		50-75	0.01	0.005	30°
MW-270-08		75-100	0.01	0.005	30°

## Availability & Compliance

- Available in Australia & New Zealand
- Indent Only, not stocked, supplied to order

# Caliper Type Inside Micrometer 280 Series

## At a Glance

- Standard: DIN 863
- Measuring the inside of a bore or hole
- Metric only



Max Range:  
5-200mm

## Features

- Satin chrome finished frame
- Pin diameter 2mm, length 5mm (only applicable to MW-280-01)
- Constant force ratchet thimble
- Locking clamp for positive locking of spindle
- Supplied in case with adjusting key



MW-280-01

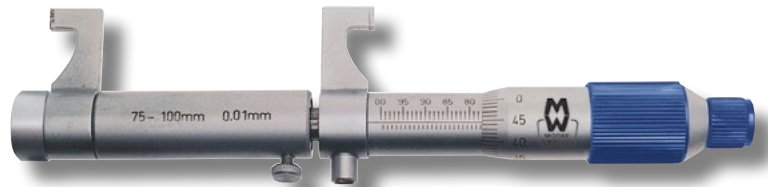

MW-280-04

## Caliper Type Inside - 280 Series

Code No		Range (mm)	Resolution (mm)	Accuracy (mm)	Setting Rings
MW-280-01		5-30	0.01	0.005	Yes
MW-280-02		25-50	0.01	0.005	Yes
MW-280-03		50-75	0.01	0.005	No
MW-280-04		75-100	0.01	0.005	No
MW-280-05		100-125	0.01	0.005	No
MW-280-06		125-150	0.01	0.005	No
MW-280-07		150-175	0.01	0.005	No
MW-280-08		175-200	0.01	0.005	No

## Availability & Compliance

- Available in Australia & New Zealand
- Indent Only, not stocked, supplied to order

# Digital Inside Micrometer 280-DDL Series

## At a Glance

- Standard: DIN 863
- Measuring the inside of a bore or hole
- Micron resolution



Max Range:  
5-150mm (0.2-6")

## Features

- Functions: mm/inch conversion, on/off, zero-setting, Battery low indication, hold, 0...ABS
- Pin diameter 2mm, length 5mm (only applicable to MW-280-01DDL)
- Satin chrome finished frame
- Constant force ratchet thimble
- Locking clamp for positive locking of spindle
- Setting rings (only applicable MW-280-01DDL and MW-280-02DDL)
- LR44/A76 Battery
- Supplied in case

## Availability & Compliance

- Available in Australia & New Zealand
- **i** Indent Only, not stocked, supplied to order
- Compliant with Australian Button Battery Standards



MW-280-01DDL



MW-280-05DDL

### Digital Inside - 280-DDL Series

Code No	Range (mm)	Range (inch)	Resolution (mm)	Resolution (inch)	Accuracy (mm)
MW-280-01DDL	<b>i</b> 5-30	0.2-1.2	0.001	0.00005	0.003
MW-280-02DDL	<b>i</b> 25-50	1-2	0.001	0.00005	0.003
MW-280-03DDL	<b>i</b> 50-75	2-3	0.001	0.00005	0.004
MW-280-04DDL	<b>i</b> 75-100	3-4	0.001	0.00005	0.004
MW-280-05DDL	<b>i</b> 100-125	4-5	0.001	0.00005	0.005
MW-280-06DDL	<b>i</b> 125-150	5-6	0.001	0.00005	0.005

# Tubular Internal Micrometer 300 Series

## At a Glance

- Standard: DIN 863
- Ideal for large diameters
- Metric only



Max Range:  
50-2000mm

## Features

- Tungsten carbide measuring faces
- Measuring faces are micro-lapped
- Satin-chromed scale and body with lock screw
- Supplied in wooden box with setting piece



## Tubular Internal - 300 Series

Code No	Range (mm)	Resolution (mm)
MW-300-01	50-250	0.01
MW-300-02	50-600	0.01
MW-300-04	150-2000	0.01

## Availability & Compliance

- Available in Australia & New Zealand

# Traditional Internal Micrometers 900 Series

## At a Glance

- Complies with: BS959
- Ideal for smaller diameters



Max Range:  
25-310mm (2-12")

## Features

- Set includes: measuring head, a set of extension rods and a spacing collar to facilitate alternative measuring ranges
- Smaller models (901, 902 & 903) have detachable extension handles
- Supplied in a case



### Traditional Internal - 900 Series - Metric

Code No	Range (mm)	Accuracy (mm)	Head Range (mm)
MW-901M	25-55	0.003	5
MW-902M	50-210	0.003	10
MW-903M	50-310	0.003	10

### Traditional Internal - 900 Series - Imperial

Code No	Range (inch)	Accuracy (inch)	Head Range (inch)
MW-901	1-2	0.0001	0.25
MW-902	2-8	0.0001	0.50
MW-903	2-12	0.0001	0.50

## Availability & Compliance

- Available in Australia & New Zealand
- Indent Only, not stocked, supplied to order

# Digital Internal Micrometer

## 300-DABI Series

### At a Glance

- Standard: DIN 863
- Micron Resolution



Max Range:  
150-2000mm (6-80")



MW-300-05DABI



### Features

- Functions: mm/inch conversion, ABS/INC, on/off, zero-setting
- IP65 Protected (dust tight and water resistant)
- Tungsten carbide measuring faces
- Measuring faces are micro-lapped
- Satin-chromed scale and body with lock screw
- Large LCD display
- LR44/A76 Battery
- Supplied in wooden box with setting peice

### Digital Internal - 300-DABI Series

Code No	Range (mm)	(inch)	Resolution (mm)	(inch)
MW-300-05DABI	150-1000	6-40	0.001	0.00005
MW-300-06DABI	150-1500	6-60	0.001	0.00005
MW-300-07DABI	150-2000	6-80	0.001	0.0005

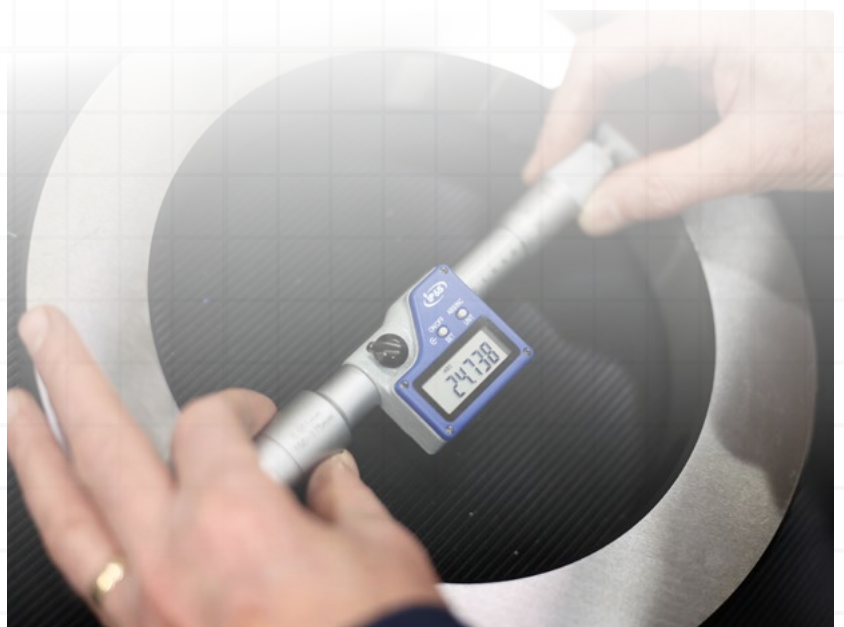

### Availability & Compliance

- Available in Australia & New Zealand
- Indent Only, not stocked, supplied to order
- Compliant with Australian Button Battery Standards





# Traditional Depth Micrometer

## At a Glance

- Complies with BS6468:1984
- Accurately measures depths of holes, slots, shoulders or projections



Max Range:  
0-300mm (0-12")

## 890 Series

- Fixed depth rod, 6.5mm diameter
- 63.5mm (2 1/2") base length, 16mm (0.63") width
- 'Speeder' type ratchet
- Lock screw

## 891 Series

- Interchangeable depth rods, 4.5mm diameter
- 63.5mm (2 1/2") base length, 16mm (0.63") width

## 892 Series

- Interchangeable depth rods, 4.5mm diameter
- 100mm (4") base length, 16mm (0.63") width
- Supplied in case

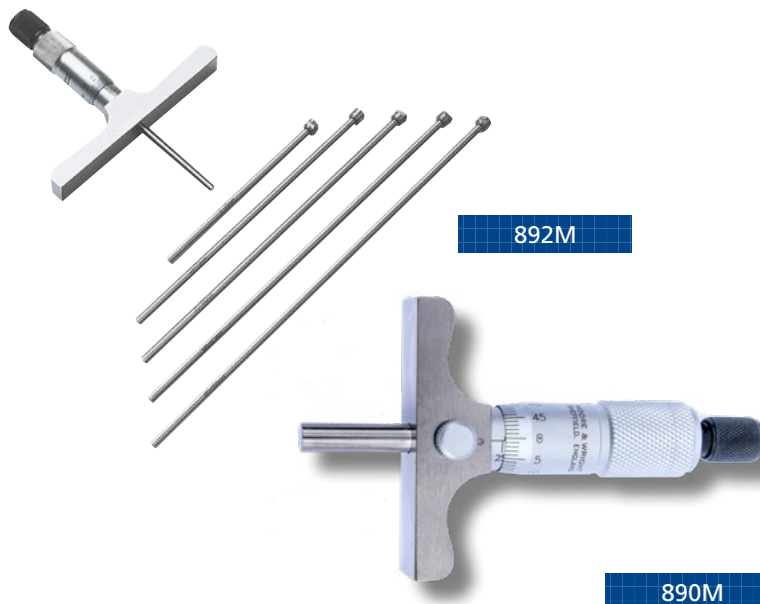

### Traditional Depth - 890 Series

Code No	Range (mm)	Resolution (mm)	Code No	Range (inch)	Resolution (inch)
MW-890M	0-25	0.01	MW-890	0-1	0.001
MW-891M75	0-75	0.01	MW-8913	0-3	0.001
MW-891M150	0-150	0.01	MW-8916	0-6	0.001
MW-891M300	0-300	0.01	MW-89112	0-12	0.001
MW-892M75	0-75	0.01	MW-8923	0-3	0.001
MW-892M150	0-150	0.01	MW-8926	0-6	0.001
MW-892M300	0-300	0.01	MW-89212	0-12	0.001

## Availability & Compliance

- Available in Australia & New Zealand
- Indent Only, not stocked, supplied to order



# Digital Depth Micrometer 305-DDL Series

## At a Glance

- Standard: DIN 863
- Micron resolution



Max Range:  
0-300mm (0-12")

## Features

- Functions: mm / inch conversion, set, on/off, zero-setting, Battery low indication, hold, 0...ABS
- IP54 Protection (dust protected and water resistant)
- Interchangeable rods (spherical ends)
- Rods are hardened and spherically lapped
- Satin chrome finished base
- Constant force ratchet on thimble
- LR44/A76 Battery
- Supplied in case



## Digital Depth - 305-DDL Series

Code No	Range		Resolution		Accuracy	Size of Base
	(mm)	(inch)	(mm)	(inch)	(mm)	(mm)
MW-305-00DDL	0-25	0-1	0.001	0.00005	0.004	100
MW-305-01DDL	0-50	0-2	0.001	0.00005	0.004	100
MW-305-02DDL	0-100	0-4	0.001	0.00005	0.005	100
MW-305-03DDL	0-150	0-6	0.001	0.00005	0.006	100
MW-305-04DDL	0-200	0-8	0.001	0.00005	0.007	100
MW-305-05DDL	0-300	0-12	0.001	0.00005	0.009	100

## Availability & Compliance

- Available in Australia & New Zealand
- Indent Only, not stocked, supplied to order
- Compliant with Australian Button Battery Standards

# Micrometer Stand 279 Series

## At a Glance

- Designed for micrometers up to 100mm

## Features

- Hammertone finish
- Adjustable angle

## Availability & Compliance

- Available in Australia & New Zealand



### Micrometer Stand

Code No	Description
MW-279-01A	Stand for micrometers up to 100mm

# Dial Bore Gauge Sets 316 Series

## At a Glance

- With interchangeable contact points
- Set of carbide tipped contact points included



Max Range:  
6-250mm

## Features

- Unique self centring device
- Supplied with dial indicator, resolution 0.01mm
- Packed as set with all necessary accessories to measure the complete range as shown



MW-316-05



## Dial Sets - 316 Series

Code No		Range (mm)	Resolution (mm)
MW-316-01		6-10	0.01
MW-316-02		10-18	0.01
MW-316-03		18-35	0.01
MW-316-04		35-50	0.01
MW-316-05		50-160	0.01
MW-316-06		160-250	0.01

## Availability & Compliance

- Available in Australia & New Zealand
- Indent Only, not stocked, supplied to order

# Digital Bore Gauge Set 316 Series

## At a Glance

- With interchangeable contact points
- Set of carbide tipped contact points included



Max Range:  
35-160mm

## Features

- Unique self centring device
- Supplied with digital indicator, resolution 0.01mm
- Packed as set with all necessary accessories to measure the complete range as shown



### Digital Sets - 316 Series

Code No	Range		Resolution		Measuring Depth	
	(mm)	(inch)	(mm)	(inch)	(mm)	(inch)
MW-316-12D	35-160	1.4-6.3	0.001	0.0005	150	6

## Availability & Compliance

- Available in New Zealand Only
- **i** Indent Only, not stocked, supplied to order
- Not Compliant with Australian Button Battery Standards

# Dial Test Indicator 420 Series

## At a Glance

- Standard: ANSI B89.1.10, DIN2270
- Automatic reversal of measuring direction



Max Range:  
0-0.8mm (0-0.030")

## Features

- High precision fully jewelled bearings
- Rotating dial
- Two dovetail clamps
- Carbide points
- Styli length: 12mm (1/2"), M1.4 thread



MW-420-03

### Dial Test - 420 Series - Metric

Code No		Range (mm)	Graduation (mm)	Dial Reading (mm)	Dial Diameter (mm)	Accuracy (mm)
MW-420-03		0.8	0.01	0-40-0	25	0.013
MW-420-04		0.8	0.01	0-40-0	37	0.013
MW-421-02		0.2	0.002	0-100-0	37	0.004
MW-422-01		1.6	0.04	0-40-0	37	0.013

### Dial Test - 420 Series - Imperial

Code No		Range (inch)	Graduation (inch)	Dial Reading (inch)	Dial Diameter (inch)	Accuracy (inch)
MW-420-03I		0.030	0.0005	0-15-0	1	0.0005
MW-420-04I		0.030	0.0005	0-15-0	1 1/2	0.0005

## Availability & Compliance

- Available in Australia & New Zealand
- Indent Only, not stocked, supplied to order



# Dial Test Indicator Accessories

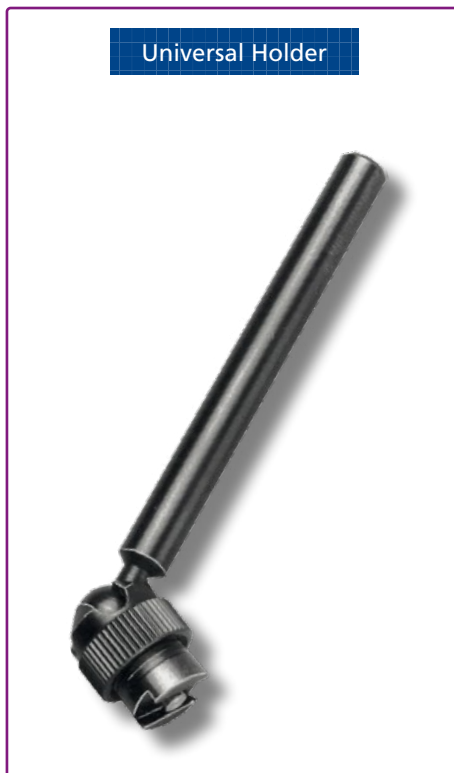

## Dial Test Accessories

Code No	Description	Code No	Description
MW-Z40010	Universal Holder	MW-Z40016	Contact point 1/2" length, 0.040" steel ball
MW-Z40012	Contact point 12mm length, 1mm steel ball	MW-Z40018	Contact point 1/2" length, 0.120" carbide ball
MW-Z40013	Contact point 12mm length, 2mm carbide ball	MW-Z40020	Dovetail stem 4mm clamping diameter
MW-Z40014	Contact point 12mm length, 3mm carbide ball	MW-Z40022	Dovetail stem 8mm clamping diameter

# Dial Indicator 400 Series

## At a Glance

- Standard: DIN 878
- Metric only



Max Range:  
0-0.8mm

## Features

- Satin chrome body
- Tungsten carbide contact point
- With double dial indicator for measuring mm stroke
- Shockproof
- Micron versions are jewelled
- Adjustable bezel with stop screw
- Supplied in foam box

MW-400-02



MW-400-03



MW-400-04



MW-400-05



MW-400-06



MW-400-06B



## Availability & Compliance

- Available in Australia & New Zealand



# Dial Indicator 400 Series

MW-400-08



MW-400-09



## Dial - 400 Series

Code No	Range (mm)	Resolution (mm)	Accuracy (mm)	Dial Diameter (mm)	Description
MW-400-01	0-1.0	0.001	0.004	58	Flat back
MW-400-02	0-1.0	0.001	0.004	58	Lug back
MW-400-03	0-3.0	0.01	0.012	42	Lug back and Flat back
MW-400-04	0-5.0	0.01	0.014	42	Lug back
MW-400-05	0-10.0	0.01	0.016	58	Flat back
MW-400-06	0-10.0	0.01	0.016	58	Lug back
MW-400-06B	0-10.0	0.01	0.02	54	Lug back / Waterproof
MW-400-08	0-30.0	0.01	0.035	58	Lug back
MW-400-09	0-50.0	0.01	0.04	58	Lug back

# Dial Indicator 401 Series

## At a Glance

- Standard: ANSI B89.1.10
- Lug back



Max Range:  
0-25mm (0-1")

## Features

- Tungsten carbide contact point
- Adjustable bezel with stop screw
- Aluminium body
- Tolerance indicators
- Flat back is optional
- Supplied in foam box



MW-401-01

MW-401-05

MW-401-02

## Dial - 401 Series

Code No	Range (mm)	Range (inch)	Resolution (mm)	Resolution (inch)	Accuracy (mm)	Bezel Diameter (mm)	Stem Diameter
MW-401-01		0-0.5		0.001	0.02	58	3/8"
MW-401-02		0-1		0.001	0.035	58	3/8"
MW-401-05	0-25	0-1	0.01	0.001	±0.035	60	8mm

## Availability & Compliance

- Available in Australia & New Zealand

# Digital Indicator 405 Series

## At a Glance

- Lug back



Max Range:  
0-25mm (0-1")



MW-405-04DB

## Features

- Functions: mm/inch conversion, ABS/INC, zero-setting
- 58mm dial face
- 8mm stem mountings
- Also supplied with flatback
- CR2032 Battery
- Supplied in foam box

### Digital - 405 Series

Code No	Range		Resolution		Accuracy	
	(mm)	(inch)	(mm)	(inch)	(mm)	(inch)
MW-405-04DB	0-12.7	0-0.5	0.01	0.0005	0.02	0.0008
MW-405-06DB	0-25	0-1	0.01	0.0005	0.03	0.0012

## Availability & Compliance

- Available in New Zealand Only
- **i** Indent Only, not stocked, supplied to order
- Not Compliant with Australian Button Battery Standards

# Digital Indicator 415 Series

## At a Glance

- Micron resolution
- Large LCD display



Max Range:  
0-50mm (0-2")



MW-415-01

## Features

- Functions: mm/inch conversion, ABS/INC, Preset
- 8mm stem mounting
- Floating zero
- CR2032 Battery
- Supplied in foam box

## Digital - 415 Series

Code No	Range		Resolution		Accuracy	
	(mm)	(inch)	(mm)	(inch)	(mm)	(inch)
MW-415-01	0-12.5	0-0.5	0.001	0.00005	0.004	0.00015
MW-415-02	0-25	0-1	0.001	0.00005	0.005	0.0002
MW-415-03	0-30	0-1.2	0.001	0.00005	0.005	0.0002
MW-415-04	0-50	0-2	0.001	0.00005	0.006	0.00025

## Availability & Compliance

- Available in New Zealand Only
- Indent Only, not stocked, supplied to order
- Not Compliant with Australian Button Battery Standards

# Digital Absolute Indicator

## 430-DABS Series

### At a Glance

- Absolute Measuring System



Max Range:  
0-50/8mm (0-2")

### Features

- Functions: tolerances, mm/inch conversion, preset capability, data-output, zero-setting, on/off
- IP54 Protection (dust protected and water resistant)
- 8mm/H7 clamping diameter
- Supplied with lugback and flat back
- USB Data Output
- CR2032 Battery
- Supplied in foam box



MW-430-01DABS

#### Digital Absolute - 430-DABS Series

Code No	Range		Resolution		Accuracy	
	(mm)	(inch)	(mm)	(inch)	(mm)	(inch)
MW-430-01DABS	0-12.5	0-0.5	0.001	0.00005	0.004	0.0002
MW-430-02DABS	0-25.4	0-1.0	0.001	0.00005	0.005	0.00025
MW-430-03DABS	0-50.8	0-2.0	0.001	0.00005	0.006	0.0003

#### Digital Absolute - 430-DABS Series

Code No	Description
MW-Y100/700USB	Data Cable-USB to suit all DABS products

### Availability & Compliance

- Available in New Zealand Only
- Indent Only, not stocked, supplied to order
- Not Compliant with Australian Button Battery Standards

# Magnetic Indicator Stand 470 Series

## At a Glance

- Powerful on/off magnetic base
- Magnetic force 80Kg / 175 LBS

## Features

- Basic type, without fine adjustment
- Can be used with indicators with or without lug back
- Accepts dial test indicators, digital indicators and normal indicators
- Extra rigid indicator holding
- V -base for mounting on rounded surfaces
- Supplied in box



## Magnetic Indicator Stand - 470 Series

Code No	Description
MW-470-01	Without fine adjustment

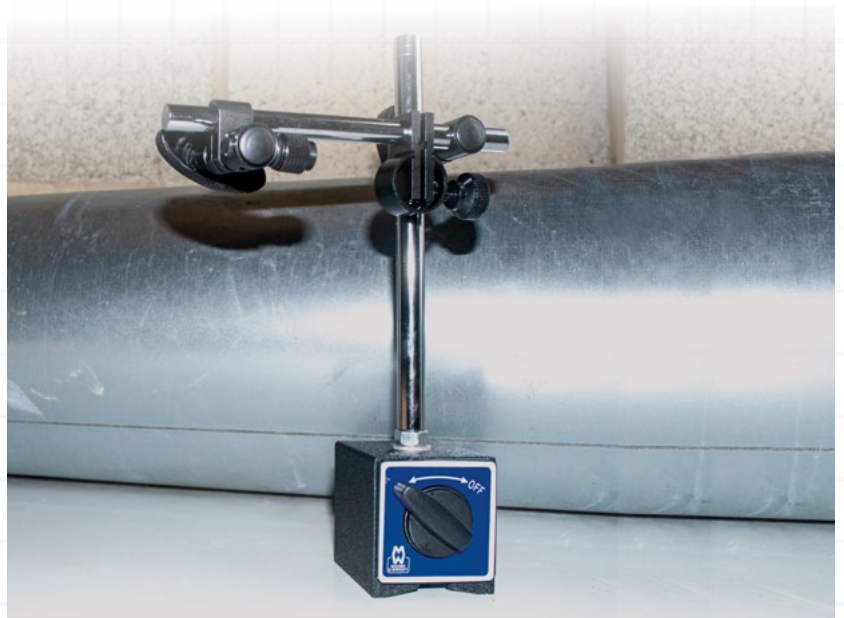

## Availability & Compliance

- Available in Australia & New Zealand

# Magnetic Indicator Stand 475 Series

## At a Glance

- Powerful on/off magnetic base
- Magnetic force 80Kg / 175lbs

## Features

- Fine adjustment,
- Can be used with indicators with or without lug back
- Accepts dial test indicators, digital indicators and normal indicators
- Rigid indicator holding
- V -base for mounting on rounded surfaces
- Supplied in box

## Availability & Compliance

- Available in Australia & New Zealand



### Magnetic Indicator Stand - 475 Series

Code No	Description
MW-475-01	With fine adjustment

# Flexible Magnetic Base 496 Series

## At a Glance

- On/off magnetic base
- Magnetic force 40kg / 85lbs

## Features

- Corrosion resistant chrome plated flex arm
- Stem mounting only
- Holds indicator rigidly in almost any position
- V -base for mounting on rounded surfaces
- Supplied in box



## Flexible Magnetic Base - 496 Series

Code No	Description
MW-496-01	Mechanically locking flexible arm

## Availability & Compliance

- Available in Australia & New Zealand



# Hydraulic Magnetic Base 485 Series

## At a Glance

- Powerful on/off magnetic base
- Magnetic force 80Kg / 175lbs

## Features

- Features a unique hydraulic central lock for all arms and swivel positions
- Fine adjustment
- Can be used with indicators with or without lug back
- Accepts dial test indicators, digital indicators and normal indicators
- Dovetail groove for clamping a dial test indicator
- Super rigid indicator holding
- V -base for mounting on rounded surfaces
- Supplied in box

## Availability & Compliance

- Available in Australia & New Zealand



### Hydraulic Magnetic Base - 485 Series

Code No	Description
MW-485-01	Universal arm with single hydraulic locking knob

# Articulating Magnetic Base Fine Adjustment 477 Series

## At a Glance

- On/off magnetic base
- Magnetic force 30Kg / 66lbs

## Features

- Versatile magnetic base that can be adjusted in almost unlimited ways
- Fine adjustment
- Can be used with indicators with or without lug back
- Accepts dial test indicators, digital indicators and normal indicators
- Rigid indicator holding
- V -base for mounting on rounded surfaces
- Supplied in box



## Articulating Magnetic Fine Adjustment - 477 Series

Code No

Description

MW-477-01

Articulating arm with fine adjustment

## Availability & Compliance

- Available in Australia & New Zealand



# Magnetic Base and Dial Indicator Set

## At a Glance

- Includes MW-475-01 and MW-400-06 dial indicator
- Combined set for extra value

## Features

- Powerful on/off magnetic base with magnetic force 80Kg / 175lbs
- Fine adjustment,
- V -base for mounting on rounded surfaces
- Indicator is shockproof
- Supplied in case



### Magnetic Base and Indicator Set

Code No	Description
MW-475-SET1	Magnetic base with MW-400-06 dial indicator

### Supplied Dial Indicator

Code No	Range (mm)	Resolution (mm)	Accuracy (mm)	Dial Diameter (mm)	Description
MW-400-06	0-10.0	0.01	0.016	58	Lug back

## Availability & Compliance

- Available in Australia & New Zealand

# Magnetic Base and Digital Indicator Set

## At a Glance

- Includes MW-475-01 magnetic base and MW-405-04DB digital indicator
- Combined set for extra value

## Features

- Powerful on/off magnetic base with magnetic force 80Kg / 175lbs
- Fine adjustment,
- V -base for mounting on rounded surfaces
- Indicator Battery CR2032
- Supplied in case



## Magnetic Base and Digital Indicator Set

Code No	Description
MW-475-SET2	Magnetic base with MW-405-04DB digital indicator

## Supplied Digital Indicator

Code No	Range		Resolution		Accuracy		Descript
	(mm)	(inch)	(mm)	(inch)	(mm)	(inch)	
MW-405-04DB	0-12.7	0-0.5	0.01	0.0005	0.02	0.0008	Flat back

## Availability & Compliance

- Available in New Zealand Only
- Not Compliant with Australian Button Battery Standards

# Traditional Precision Combination Set CSM300

## At a Glance

- For various precision measuring and marking applications

## Features

- Includes square, protractor and centre heads with fully hardened and ground datum faces to resist wear
- Centrally mounted protractor vial allows unrestricted viewing with full 360° scale plate, graduated 0-180°-0
- Satin chrome scale plate on protractor
- Unique rule clamp allows positive location and clamping
- Square head offers the following fixed angles: 15°, 30°, 45°, 60°, 75° & 90°
- Centre head offers a fixed 90° angle, for finding the centre of round bar stock up to 120mm diameter
- Fully hardened and tempered precision rules with clipped corner on rule to maximise capability
- Deeply etched graduations on both sides for ease of reading and long life
- Replacement heads and clamp screw available
- Supplied in case



## Precision Combination Sets

Code No	Type	Range	Accuracy
MW-CSM300	Metric Only		
MW-CSME12	Metric/Imperial		

## Replacement Rulers

MW-CSRM300	Metric, 300mm	mm and 0.5mm on both sides; numbered every 10mm
MW-CSRM600	Metric, 600mm	mm and 0.5mm on both sides; numbered every 10mm
MW-CSRME12	mm/in, 300mm (12")	Metric graduations: in 0.5mm, numbered every 10mm Imperial graduations: 32nds and 64ths numbered every 1/8"
MW-CSRME24	mm/in, 600mm (24")	Metric graduations: in 0.5mm, numbered every 10mm. Imperial graduations: 32nds and 64ths numbered every 1/8"

## Availability & Compliance

- Available in Australia & New Zealand

# Workshop Combination Set 521 Series

## At a Glance

- For various measuring and marking applications

## Features

- Includes square, protractor and centre heads
- Hardened and ground slide ways
- 300mm/12" stainless steel rule
- Engraved graduations; one side metric, one side imperial
- Supplied in case



## Workshop Combination Set - 521 Series

Code No	Range	Protractor Accuracy
MW-521-01	180°	5 minutes

## Availability & Compliance

- Available in Australia & New Zealand

# Universal Bevel Protractor

## At a Glance

- For accurate measurement of angles where high precision is needed

## Features

- High quality hardened and ground stainless steel
- High precision satin chromed scale
- Minimum reading 5 minutes
- Magnifying glass for easy reading
- Fine adjustment and acute angle attachment
- 300mm (12") and 150mm (6") rule
- Supplied as set in plastic box



### Universal Bevel Protractor

Code No	Range
MW-500-01	360°

## Availability & Compliance

- Available in Australia & New Zealand

# Dial Bevel Protractor

## At a Glance

- For accurate measurement of angles where high precision is needed

## Features

- High quality hardened and ground stainless steel
- High precision satin chromed scale
- Minimum reading 5 minutes
- High quality indicator
- Fine adjustment and acute angle attachment
- 300mm (12") and 150mm (6") rule
- Supplied as set in plastic box



## Dial Bevel Protractor

Code No	Range	Accuracy
MW-510-01	360°	5 minutes

## Availability & Compliance

- Available in Australia & New Zealand



# Digital Universal Bevel Protractor

## At a Glance

- For accurate measurement of angles where high precision is needed
- 360° measuring range (4 x 90°)

## Features

- Functions: deg/min/sec and decimals, on/off, zero-setting
- Manufactured from stainless steel
- Resolution 30°
- Fine adjustment
- 150, 200 and 300mm blades
- Supplied with acute angle attachment
- CR2032 Battery
- Supplied in case



### Digital Universal Bevel Protractor

Code No	Range	Accuracy
MW-500-01D	 360°	5 minutes

## Availability & Compliance

- Available in New Zealand Only
-  Indent Only, not stocked, supplied to order
- Not Compliant with Australian Button Battery Standards

# Digital Protractor 505 Series

## At a Glance

- Ideal for the measurement and duplication of angles

## Features

- Functions: Direction, hold function, on/off, zero-setting
- Reversible reading
- Large LCD display
- Strong magnets on all blade edges
- Easy-to-use and strong lock device
- CR2032 Battery
- Supplied in case



MW-505-01

## Digital Protractor - 505 Series

Code No		Size	Range	Resolution	Accuracy
MW-505-01		100mm / 4"	360°	0.05°	0.2°
MW-505-02		200mm / 8"	360°	0.05°	0.2°
MW-505-03		300mm / 12"	360°	0.05°	0.2°

## Availability & Compliance

- Available in New Zealand Only
-  Indent Only, not stocked, supplied to order
- Not Compliant with Australian Button Battery Standards

# Digital Angle Rule 506 Series

## At a Glance

- Ideal for the measurement and duplication of angles

## Features

- Functions: Hold function, on/off, zero-setting  
Reversible reading
- Large LCD display
- Easy-to-use and strong lock device
- Stainless steel rule blades with mm scale
- CR2032 Battery
- Supplied in case



MW-506-01

### Digital Angle Rule

Code No	Range (mm)	Resolution
MW-506-01	200	0.05°
MW-506-02	300	0.05°

## Availability & Compliance

- Available in New Zealand Only
- **i** Indent Only, not stocked, supplied to order
- Not Compliant with Australian Button Battery Standards

# Protractor with Rule

## 946 Series

### At a Glance

- For the quick and easy measurement of angles in projects, woodworking etc.

### Features

- Made of tool steel
- Satin chromed laser engraved scale
- Robust and durable design



MW-946-01

### Protractor - 946 Series

Code No		Length (mm)	Diameter of Scale (mm)
MW-946-01		120	80
MW-946-02		150	120
MW-946-03		200	150
MW-946-04		300	200

### Availability & Compliance

- Available in Australia & New Zealand
- Indent Only, not stocked, supplied to order

# Traditional Depth Gauges

## At a Glance

- Ideal for the easy measurement of depth and angles

## Features Depth Gauge

- Available with either reversible base or protractor
- Full range rule adjustment
- Readings can be fixed by means of a locknut
- Rules graduated on both sides
- Length of blade 195mm / 7.68"

## Reversible Base Type

- Accurately ground top and bottom faces allow base to be reversed, for use in confined spaces

## Protractor Type

- Protractor plate is graduated 0° - 180° - 0° degrees
- Scale resolution 1/2 degree

## Availability & Compliance

- Available in Australia & New Zealand
- **i** Indent Only, not stocked, supplied to order

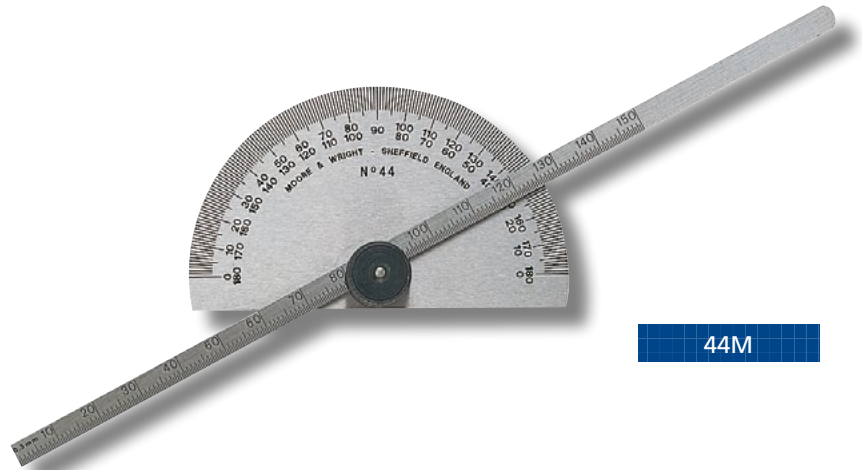

44M



43M

### Traditional Depth Gauge - 0-150mm

Code No	Description	Rule Graduations	Width (mm)	Thickness (mm)	Size of Base (mm)
MW-43M	Reversible Base	1, 0.5mm	5.5	1.0	18, 56
MW-44M	Protractor	1, 0.5mm	5.5	1.0	79

### Traditional Depth Gauge - 0-6"/ 0-150mm

Code No	Description	Rule Graduations	Width (inch)	Thickness (inch)	Size of Base (inch)
MW-43	<b>i</b> Reversible Base	1/32", 1mm	0.22	0.04	0.71, 2.21
MW-44	<b>i</b> Protractor	1/32", 1mm	0.22	0.04	3.11

# Traditional Engineers' Square

## At a Glance

- Standard: To BS939 / Grade B
- Accurately check and mark angles, verify the squareness of straight edges and lines

## Features

- Precision ground blade and stock
- Blind rivetted construction
- Hardened and tempered blades
- Supplied in box



4006R

## Traditional Engineers' Square - Grade B

Code No	Blade Length (mm)	Blade Length (inch)	Approx. Stock Length (mm) (inside face)
MW-400/3	75	3	49
MW-400/4	100	4	56
MW-400/6	150	6	82
MW-400/9	225	9	108
MW-400/12	300	12	139



## Availability & Compliance

- Available in Australia & New Zealand

# Traditional Engineers' Square

## Traditional Engineers' Square - 400 Series - Tolerances - (Microns)

	Size of Square				
	3" 75mm	4" 100mm	6" 150mm	9" 225mm	12" 300mm
Straightness of Blade Edge	8	8	8	8	12
Parallelism of Blade Edges	8	8	8	12	12
Flatness of Working Faces of Stock (any deviation must be concave)	4	6	6	8	8
Parallelism of Working Faces of Stock	5	5	5	8	8
Parallelism of Side Faces of Stock	25	25	25	50	50
Squareness of Side Faces of Stock to Working Faces of Stock	57	57	75	114	134
Squareness of Edges of Blade to Side Faces of Stock	15	15	15	15	15
Squareness of Edges of Blade to Working Faces of Stock	16	16	16	16	24
Lateral Squareness of Blade	125	250	250	375	375

## Dimensions

Square Size Faces	Blade		Stock				Inner Working	
	A	B	C	D	E	F	G	H
3" (75mm)	104.8	25.4	1.42	68.5	25.4	12.7	49.3	79.4
4" (100mm)	130.2	25.4	1.42	76.2	25.4	12.7	57.0	104.8
6" (150mm)	181.0	25.4	1.42	101.6	25.4	12.7	82.4	155.6
9" (225mm)	273.1	38.1	3.15	139.7	38.1	19.05	107.9	234.95
12" (300mm)	355.6	44.4	3.15	177.8	44.4	22.2	139.7	311.2

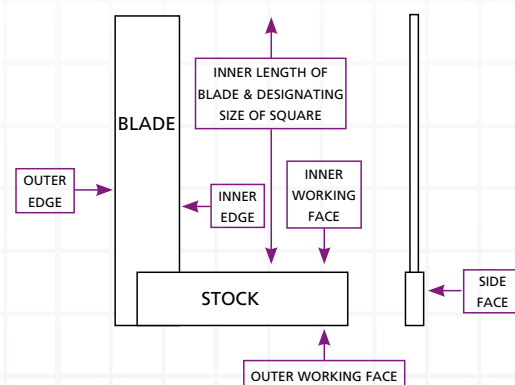
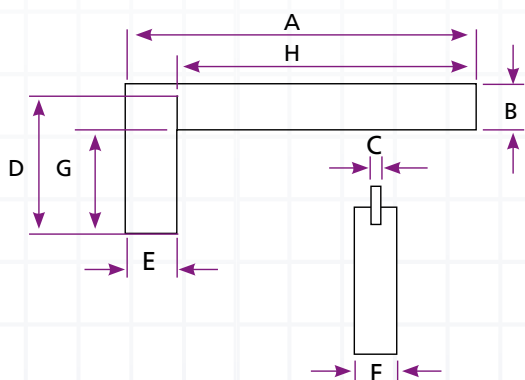

# Precision Engineers' Bevelled Edge Square

## At a Glance

- Standard: DIN 875 Grade 0
- Accurately check and mark angles



MW-910-01R

## Features

- Made of heat treated steel
- Precision ground and micro-lapped
- 2 knife-form sides with angle of 40°

## Precision Engineers' Bevelled Edge Square

Code No	Description
MW-910-01	 40 x 30mm
MW-910-02	 50 x 40mm
MW-910-03	 75 x 50mm
MW-910-04	 100 x 70mm
MW-910-05	 150 x 100mm
MW-910-06	 200 x 130mm

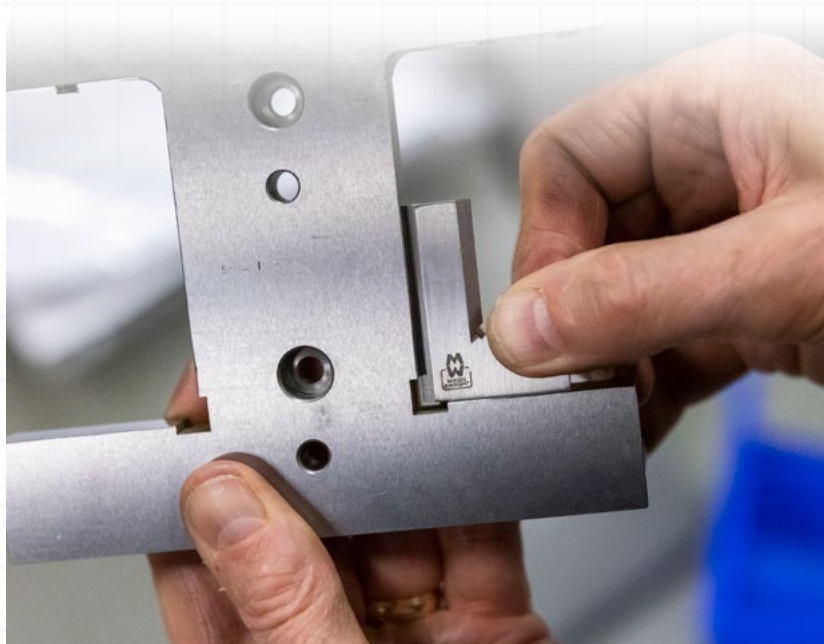

## Availability & Compliance

- Available in Australia & New Zealand
-  Indent Only, not stocked, supplied to order



# Sliding 'T' Squares

## At a Glance

- Practical time saving tool for marking-out applications

## Features

- Suitable for use as a parallel or as a double square
- Working surfaces of the stock are ground
- The blade is hardened, tempered and has a satin chrome finish

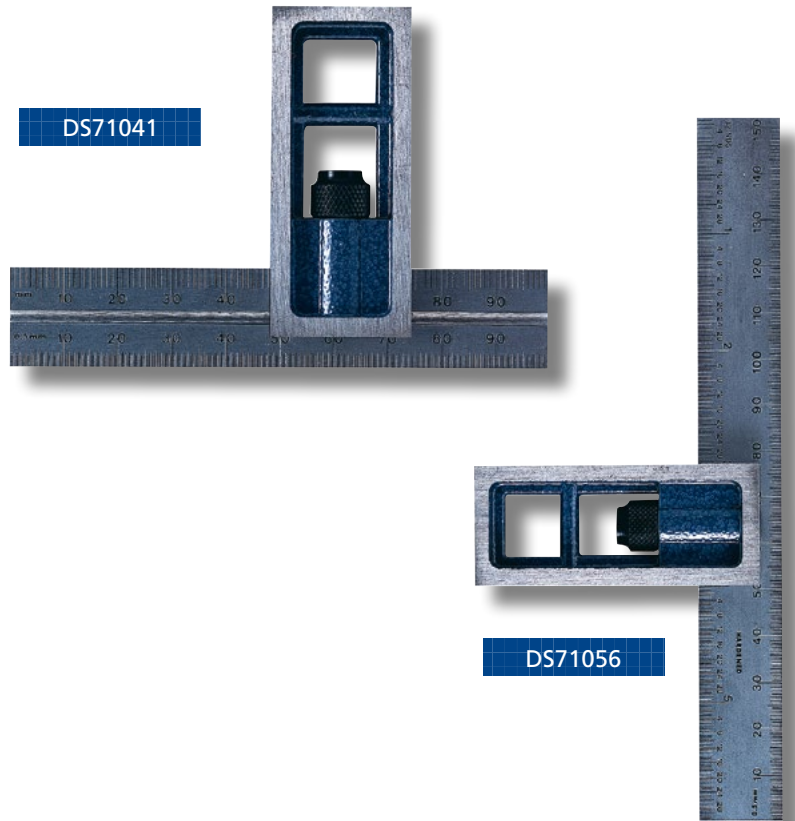

## Sliding 'T' Squares

Code No	Length		Graduation		Stock Length (mm)
	(mm)	(inch)	(mm)	(inch)	
MW-DS71041	100		1, 0.5		62
MW-DS71051	150		1, 0.5		62
MW-DS71044	100	4	0.5, 1	1/16	62
MW-DS71056	150	6	0.5, 1	1/16	62

## Availability & Compliance

- Available in Australia & New Zealand
- **i** Indent Only, not stocked, supplied to order

# Traditional Inside & Outside Calipers

## At a Glance

- Standard: BS3123
- Traditional hand tools for scribing and measuring
- Manufactured from polished tool

## Firm Joint Calipers

- A large headed nut & screw assembly provides a firm & rigid friction joint, with no play
- Sizes listed are the effective leg length which is measured from the joint assembly

## Spring Joint Calipers

- Bow spring ensures uniform tension over working range
- Centrally mounted adjustment screw offers finer setting than firm joint type

## Spring Dividers

- Points are hardened to over 550Hv
- Bow spring ensures uniform tension over working range
- Centrally mounted adjustment screw
- Nominal size is the distance between the centre of the roller and the working ends of the legs.

## Availability & Compliance

- Available in Australia & New Zealand



Standard:  
BS3123

3316R

526R

3306R

516R

506R



### Traditional Inside Calipers Firm Joint

Code No	Size (mm)	Size (inch)
MW-330/6	150	6
MW-330/8	200	8
MW-330/12	300	12

Note: Firm joint caliper capacities are generally 1/3 greater than the effective leg length.

### Traditional Outside Calipers Firm Joint

Code No	Size (mm)	Size (inch)
MW-331/6	150	6
MW-331/8	200	8
MW-331/12	300	12
MW-331/18	450	18
MW-331/24	600	24

### Dividers & Inside / Outside Calipers Spring Joint

Size (mm)	Size (inch)	Code No	Description	Code No	Description	Code No	Description
75	3	MW-50/3	Divider	MW-51/3	Inside	MW-52/3	Outside
100	4	MW-50/4	Divider	MW-51/4	Inside	MW-52/4	Outside
150	6	MW-50/6	Divider	MW-51/6	Inside	MW-52/6	Outside
200	8	MW-50/8	Divider	MW-51/8	Inside	MW-52/8	Outside
250	10	MW-50/10	Divider	MW-51/10	Inside	MW-52/10	Outside
300	12	MW-50/12	Divider	MW-51/12	Inside	MW-52/12	Outside

# Traditional Hermaphrodite Calipers

## At a Glance

- Standard: BS3123
- Traditional hand tools for scribing and measuring
- Manufactured from polished tool steel

## Firm Joint Adjustable Point

- A large headed nut and screw assembly provides a firm and rigid friction joint, with no play
- Sizes listed are the effective leg length which is measured from the joint assembly
- Leg which holds the round adjustable hardened point is offset
- Model 341 has a locating spur on the straight leg

## Spring Joint

- The marking leg is hardened to over 550Hv at the point
- Bow spring ensures uniform tension over working range
- Centrally mounted adjustment screw offers finer setting than firm joint type



## Traditional Hermaphrodite Calipers

Code No	Size (mm)	Size (inch)	Description	Pack Quantity
MW-341	125	5	Firm Joint	5
MW-336/6	150	6	Firm Joint	5
MW-56	150	6	Spring Joint	5

## Availability & Compliance

- Available in Australia & New Zealand

# Traditional Surface Gauges

## At a Glance

- Designed for precise marking out operations

## Features

- Hardened and tempered steel base, ground on one end and bottom face
- Vee groove for locating on cylindrical workpieces
- Two retractable locating pins
- Radial grooves in the side facilitate comfortable handling
- One handed fine adjustment
- Supplied with two interchangeable pillars and one 4mm diameter scriber
- Surface gauges can be used for mounting dial test indicators with either a 4mm or 6.35mm (1/4") mounting spigot.



E102B

## Availability & Compliance

- Available in Australia & New Zealand

### Traditional Surface Gauges

Code No	Description	Size of Base	Height (mm)	(inch)
MW-E101B	Universal	80 x 65mm, 3 1/8 x 2 1/2"	225 & 300	9 & 12
MW-E102B	Universal	105 x 85mm, 4 1/8 x 3 3/8"	300 & 450	12 & 18

# Traditional Feeler Gauge Set - Precision Range

## At a Glance

- Standard: DIN 2275
- Precise setting and measurement of small gaps in automotive and industrial applications

## Features

- All blades are hardened, tempered and polished
- Nominal thickness marked on each blade



393M-20-A



388M-13-B



## Availability & Compliance

- Available in Australia & New Zealand

# Traditional Feeler Gauge Set

## Precision Range

### Traditional Feeler Gauge Set - Precision Range - Imperial

Code No	Blade Type	Length (inch)	No. of Blades	Thickness x 0.001"	Width (inch)	Locking Screw
MW-911-10-B	Tapered	4	10	1.5, 2, 3, 4, 6, 8, 10, 12, 15, 25	0.4	No
MW-1246-10-A	Rounded	6	10		0.5	No
MW-12412-10-A	Rounded	12	10		0.5	No
MW-12-26-A	Rounded	3	26	1.5, 2, 2.5, 3, 4, 5, 6, 7, 8, 9, 10, 11, 12, 13, 14, 15, 16, 17, 18, 19, 20, 21, 22, 23, 24, 25	0.5	No

### Traditional Feeler Gauge Set - Precision Range - Metric

Code No	Blade Type	Length (mm)	No. of Blades	Thickness x 0.01mm"	Width (mm)	Locking Screw
MW-911M-10-B	Tapered	100	10	5, 10, 15, 20, 30, 40, 50, 60, 70, 80	12.8	Yes
MW-391M-11-A	Rounded	100	11	5, 10, 15, 20, 25, 30, 40, 50, 60, 70, 80	12.8	No
MW-387M-13-A	Rounded	75	13	3, 4, 5, 6, 7, 8, 9, 10, 15, 20, 30, 40, 50	12.8	Yes
MW-388M-13-B	Tapered	100	13		10.0	Yes
MW-393M-20-A	Rounded	75	20	5, 10, 15, 20, 25, 30, 35, 40, 45, 50, 55, 60, 65, 70, 75, 80, 85, 90, 95, 100	12.8	No
MW-390M-20-B	Tapered	100	20		10.0	No
MW-395M-20-A	Rounded	150	20		12.8	No
MW-399M-20-A	Rounded	300	20		12.8	Yes
MW-390M-32-B	Tapered	100	32	3, 4, 5, 6, 7, 8, 9, 10, 13, 15, 18, 20, 23, 25, 28, 30, 33, 35, 38, 40, 45, 50, 55, 60, 63, 65, 70, 75, 80, 85, 90, 100	10	No

# Traditional Screw Cutting Gauges

## At a Glance

- Accurately milled angles for precise evaluation of thread form

## Features

- Suitable for most standard metric and imperial thread forms

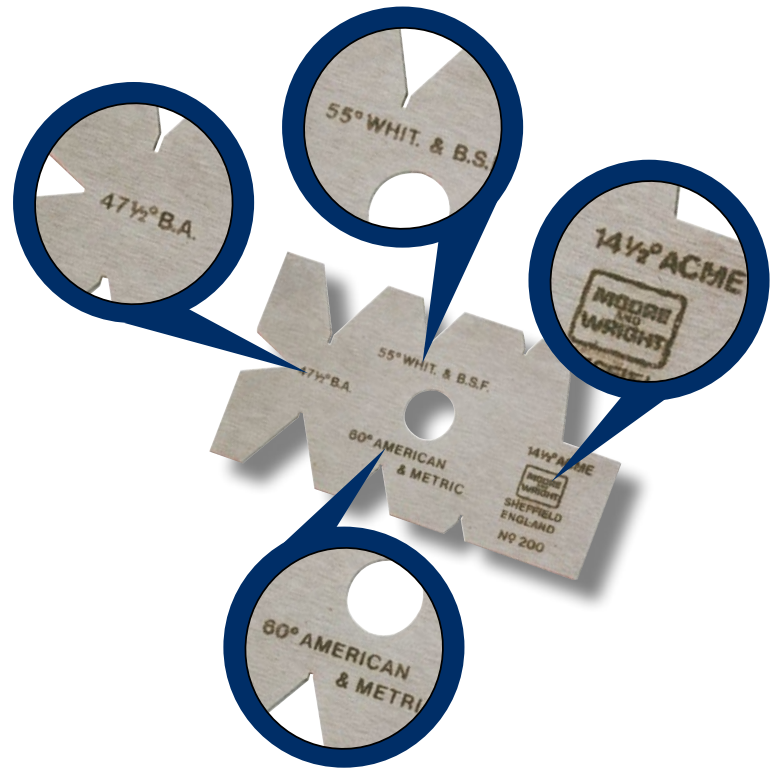

## Traditional Screw Cutting Gauges

Code No

Description

MW-200

Thread form: SI, ISO, US Std. 60°.  
Thread form: Whitworth 55°.  
Thread form: British Association (BA). 47.5°. Thread form: ACME. 14.5°.

## Availability & Compliance

- Available in Australia & New Zealand



# Traditional Radius Gauges

## At a Glance

- Designed to check both internal and external radii Accurately milled steel blades

## Features

- Accurately milled steel blades
- Marked with nominal size on each blade
- Mounted either on a ring or in a steel sleeve



204M



206M

### Traditional Radius Gauges - Metric - 0.75-13mm

Code No	Range (mm)	Graduation (mm)	No. of Blades	Description
MW-204M	0.75-5	0.25	18	Ring
MW-206M	0.75-5	0.25	18	Sleeve
MW-204MA	5.5-13	0.5	16	Ring
MW-206MA	5.5-13	0.5	16	Sleeve

### Traditional Radius Gauges - Imperial - 1/32-33/64"

Code No	Range (inch)	Graduation (inch)	No. of Blades	Description
MW-204	1/32 - 17/64	1/64	16	Ring
MW-206	1/32 - 17/64	1/64	16	Sleeve
MW-204A	9/32 - 33/64	1/64	16	Ring
MW-206A	9/32 - 33/64	1/64	16	Sleeve

## Availability & Compliance

- Available in Australia & New Zealand

# Traditional Screw Pitch Gauges

## 800 Series

### At a Glance

- Designed to check both internal and external thread forms

### Features

- Accurately milled steel blades
- Marked with nominal size on each blade
- All blades fixed in a steel sleeve
- Screw cutting gauge included

Note: SI (System International) metric blades should not be used to check ISO (International Standards Organisation) metric threads due to interference of the thread forms; but ISO metric blades can be used to check SI metric threads.



801



804

### Availability & Compliance

- Available in Australia & New Zealand

# Traditional Screw Pitch Gauges 800 Series

## Traditional Screw Pitch Gauges - 800 Series - Metric

Code No	Description	No. of Blades	Threads per mm	Note
MW-804	S.I. Metric & Whitworth	49	<b>Metric:</b> 0.4, 0.5, 0.7, 0.75, 0.8, 0.9, 1.0, 1.25, 1.50, 1.75, 2.0, 2.5, 3.0, 3.5, 4.0, 4.5, 5.0, 5.5, 6.0, 6.5, 7.0 <b>Imperial:</b> 4, 4.5, 5, 6, 7, 8, 9, 10, 11, 12, 13, 14, 16, 18, 19, 20, 22, 24, 25, 26, 28, 30, 32, 36, 40, 48, 60	Screw Cutting Gauge included 60 degrees and 55 degrees
MW-801	S.I. Metric	30	0.25, 0.3, 0.35, 0.4, 0.45, 0.5, 0.55, 0.6, 0.65, 0.7, 0.75, 0.8, 0.85, 0.9, 1.0, 1.1, 1.2, 1.25, 1.3, 1.4, 1.5, 1.6, 1.7, 1.75, 1.8, 1.9, 2.0, 2.5, 3.0	Screw Cutting Gauge included 60 degrees
MW-809	ISO Metric	22	0.35, 0.4, 0.45, 0.5, 0.6, 0.7, 0.75, 0.8, 1.0, 1.25, 1.5, 1.75, 2.0, 2.5, 3.0, 3.5, 4.0, 4.5, 5.0, 5.5, 6.0	Screw Cutting Gauge included 60 degrees

## Traditional Screw Pitch Gauges - 800 Series - Imperial

Code No	Description	No. of Blades	Threads per inch	Note
MW-799	American National	30	4, 4.5, 5, 5.5, 6, 7, 8, 9, 10, 11, 11.5, 12, 13, 14, 15, 16, 18, 20, 22, 24, 26, 27, 28, 30, 32, 34, 36, 38, 40, 42	n/a
MW-800	Whitworth	28	4, 4.5, 5, 6, 7, 8, 9, 10, 11, 12, 13, 14, 16, 18, 19, 20, 22, 24, 25, 26, 28, 30, 32, 36, 40, 48, 60	Screw Cutting Gauge included 55 degrees
MW-806	Unified	30	4, 4.5, 5, 5.5, 6, 7, 8, 9, 10, 11, 11.5, 12, 13, 14, 15, 16, 18, 20, 22, 24, 26, 27, 28, 30, 32, 34, 36, 38, 40, 42	n/a

# Traditional Drill & Standard Wire Gauges

## At a Glance

- Fast and easy identification of drill and wire sizes

## Drill Gauges

- Made from high grade tool steel, with a brushed finish
- Marked with nominal size of each hole

## Standard Wire Gauges

- Two part space saving design, with corner pivot
- Marked with nominal size of each slot
- Made from high grade tool steel, with a brushed finish

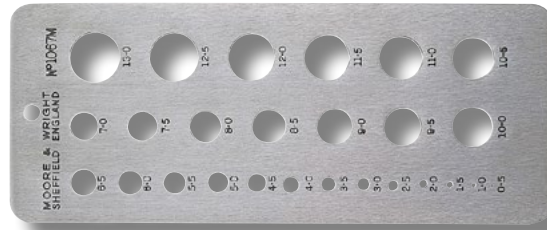

1067M

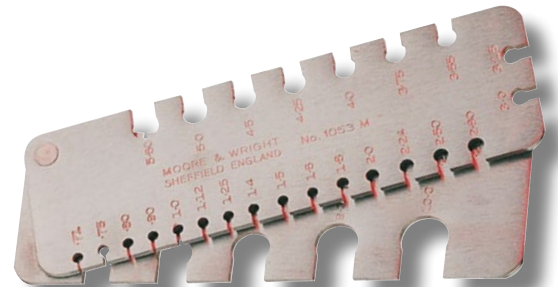

1053M

### Traditional Standard Wire Gauges

Code No	No. of Slots	Range of Slot Size (mm)	Range of Slot Size (SWG)
MW-1053M	40	6	0.2-10.0
MW-1052	36	8	1-36

### Traditional Drill Gauges

Code No	No. of Slots	Range of Hole Size (mm)	Graduation (mm)
MW-1067M	26	0.5-13.0	0.5
MW-1066M	96	0.5-10.0	0.1

## Availability & Compliance

- Available in Australia & New Zealand

# Traditional Engineers' Level EL Series

## At a Glance

- Accurate and precise setting of lathes and machinery

## Features

- Main vial protected by rotating shroud
- Main vial sensitivity of 1 minute
- Each level is fitted with a main, cross and plumb vial
- Vial solution maintains colour and fluidity under all workshop conditions
- Precision ground cast base with vee groove for location on cylindrical work
- Supplied in case



ELS



ELM

## Traditional Engineers' Level

Code No	Length		Width		Height		Resolution	
	(mm)	(inch)	(mm)	(inch)	(mm)	(inch)	(mm)	(inch)
MW-ELS	165	6.5	34	1.34	46	1.81	0.3 per metre	0.0035 per foot
MW-ELM	310	12	36	1.42	58	2.28	0.3 per metre	0.0035 per foot

## Availability & Compliance

- Available in Australia & New Zealand

# Engineers' Level 550 Series

## At a Glance

- Accurate and precise setting of lathes and machinery
- With four ground measuring faces

## Features

- Features zero-point adjustment
- With V-slot on base
- Made of cast iron, solid and rigid construction
- Sub-level tube
- Supplied in case



## Engineers' Level - 550 Series

Code No	Size of Base (mm)	Sensitivity (mm/m)
MW-550-03	 200	0.02

## Availability & Compliance

- Available in Australia & New Zealand
-  Indent Only, not stocked, supplied to order

# Mini Level ELT Series

### At a Glance

- Handy pocket sized level for the quick checking of machinery etc

### Features

- Machined from a solid block of carbon steel
- Ultra compact dimensions and a single vial
- Supplied on retail card



Mini Level - ELT Series				
Code No	Length (mm)	Width (mm)	Height (mm)	Accuracy
MW-ELT001XR	65	20	348	1°

### Availability & Compliance

- Available in Australia & New Zealand



# Digital Mini-Mag Level 570 Series

## At a Glance

- Accurate measuring of angles and inclines

## Features

- Functions: on/off, zero, tilt %
- Embedded magnets on two sides
- Wireless connectivity (MW-570-01W)
- 9V Battery
- Supplied in box



MW-570-01W

## Digital Mini-Mag - 570 Series

Code No	Length (mm)	Width (mm)	Height (mm)	Accuracy	Resolution
MW-570-01	60	60	35	0.2°	0.05°
MW-570-01W	 60	60	35	0.2°	0.05°



## Availability & Compliance

- Available in Australia & New Zealand
-  Indent Only, not stocked, supplied to order



# IP65 Magnetic Digital Level 575 Series

## At a Glance

- Accurate measuring of angles and inclines



MW-575-01DIP

## Features

- Functions: on/off, zero, tilt %, level
- Relative angle measuring
- IP65 Protected (dust tight and water resistant)
- Magnets on bottom measuring surface
- Built in Battery with Micro USB charging
- Wireless connectivity (MW-575-01WIP)
- Supplied in case

### IP65 Magnetic Digital - 575 Series

Code No	Length (mm)	Width (mm)	Height (mm)	Accuracy	Resolution
MW-575-01DIP				0.2°	0.05°
MW-575-01WIP				0.2°	0.05°

## Availability & Compliance

- Available in Australia & New Zealand
- **i** Indent Only, not stocked, supplied to order
- Compliant with Australian Button Battery Standards



# Digital Level 580 Series

## At a Glance

- Accurate alignment and measurement of angles and inclines

## Features

- Functions: on/off, zero, tilt %, bevel, laser & level
- Precision inclinometer sensor
- CNC machined super flat edge
- Heavy duty aluminium alloy body, chrome finish
- Laser accurately extends level capabilities
- Strong magnets on underside
- 9V Battery

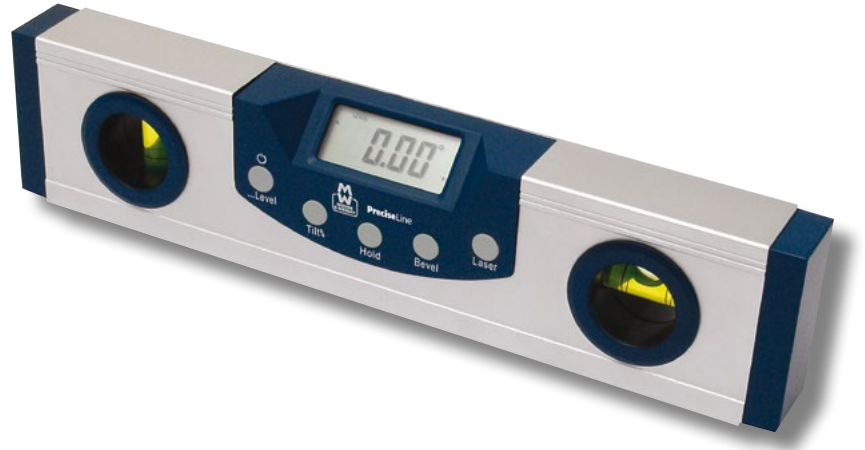

MW-580-01

## Digital Level - 580 Series

Code No	Size (mm)	Size (inch)	Resolution (mm)	Accuracy °
MW-580-01	150	6	0.05°	0.2
MW-580-02	225	9	0.05°	0.2
MW-580-03	 600	24	0.05°	0.2

## Availability & Compliance

- Available in Australia & New Zealand
-  Indent Only, not stocked, supplied to order

# Traditional Angle Plates

## At a Glance

- Standard: BS5535 Grade B
- For quick mounting of fixtures for machine setup, layout or inspection

## Features

- Manufactured from close grained cast iron
- Heat stabilised to prevent distortion
- Machined to tolerance on all four edges and two faces (four faces on open end version)
- Supplied in box



### Traditional Angle Plates

Code No	Description	Length (mm)	Length (inch)	Width (mm)	Width (inch)	Height (mm)	Height (inch)
MW-E200	Webbed	100	3.94	60	2.36	80	3.15
MW-E201	Webbed	131	5.15	86	3.38	106	4.17
MW-E202	Webbed	160	6.30	100	3.94	125	4.92
MW-E204	Webbed	200	7.87	125	4.92	160	6.30
MW-E301	Open End	125	4.92	80	3.15	100	3.94
MW-E302	Open End	160	6.30	100	3.94	125	4.92
MW-E304	Open End	200	7.87	125	4.92	160	6.30

## Availability & Compliance

- Available in Australia & New Zealand
- Indent Only, not stocked, supplied to order

# Steel Gauge Blocks

## 700 Series

### At a Glance

- Accurate and precise setting of machinery and measuring systems
- Hardened to HV820 (HRC65)

### Features

- Made from high quality stress relieved alloy steel
- Excellent rigidity
- Size and serial number are engraved on each individual gauge block
- Available in 2 grades
  - Grade 1 for Inspection
  - Grade 2 for Workshop
- All sets have a MOORE & WRIGHT certificate
- All sets can be issued with a UKAS certificate at extra cost

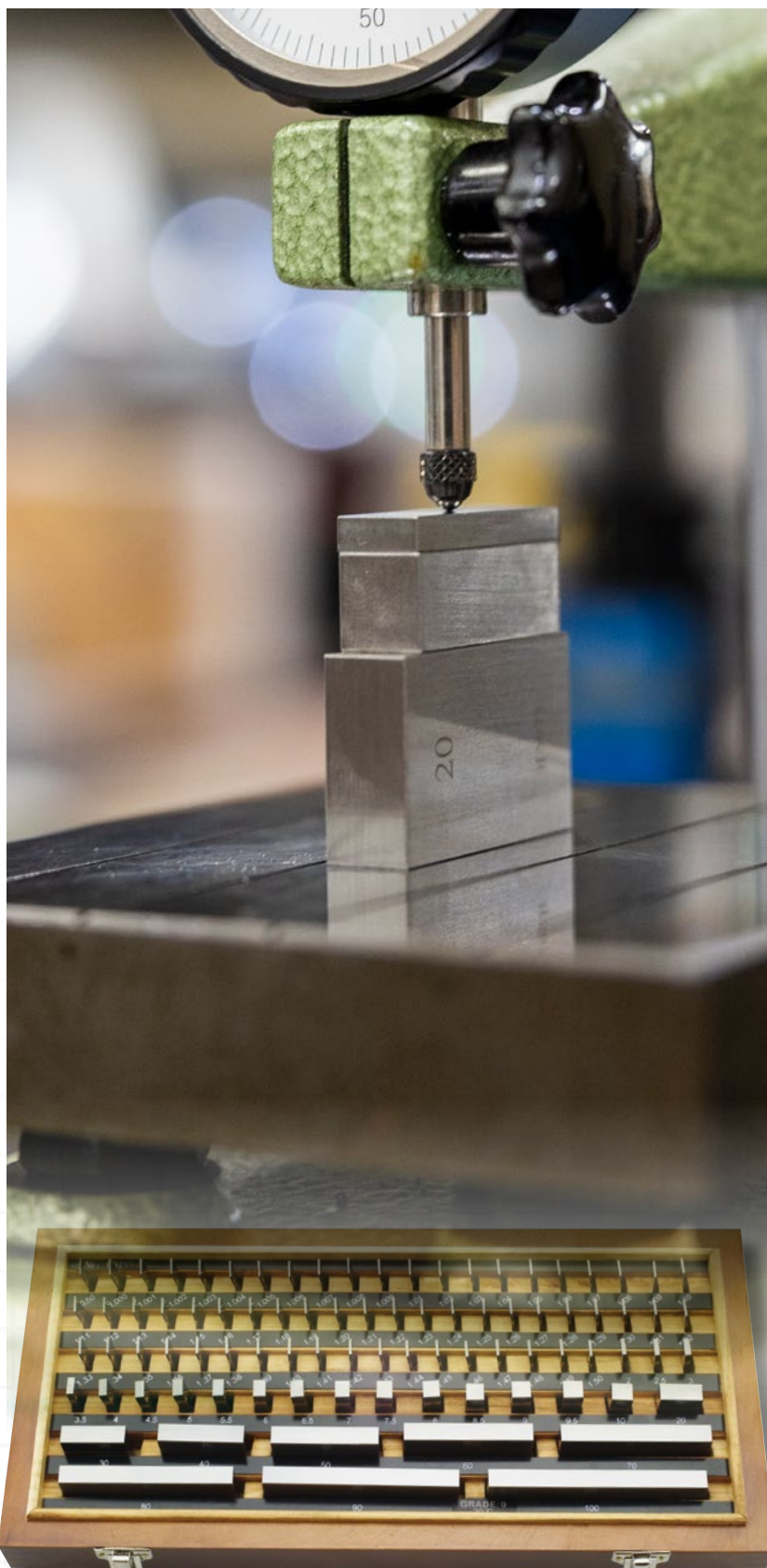

### Availability & Compliance

- Available in Australia & New Zealand
- **i** Indent Only, not stocked, supplied to order









MW-700-05



# Steel Gauge Blocks 700 Series

Block Set Configuration							
No. Blocks	Nominal Size	Quantity	Step (mm)	No. Blocks	Nominal Size	Quantity	Step (mm)
103	1.005	1		87	1.001-1.009	9	0.001
	1.01-1.49	49	0.01		1.01-1.49	49	0.01
	0.50-24.50	49	0.5		0.50-9.50	19	0.5
	25.0-100.0	4	25		10.0-100.0	10	10

Block Set Configuration							
No. Blocks	Nominal Size	Quantity	Step (mm)	No. Blocks	Nominal Size	Quantity	Step (mm)
47	1.005	1		32	1.005	1	
	1.01-1.09	9	0.01		1.01-1.09	9	0.01
	1.10-1.90	9	0.01		1.10-1.90	9	0.1
	1.0-24.0	24	1		1.0-9.0	9	1
	25.0-100.0	4	25		10.0-30.0	3	10
				60.0	1		

Steel Gauge Blocks - 700 Series			
Code No		No. of Blocks	Description
MW-700-02		103	Grade 1
MW-700-03		103	Grade 2
MW-700-05		87	Grade 1
MW-700-06		87	Grade 2
MW-700-08		47	Grade 1
MW-700-09		47	Grade 2
MW-700-11		32	Grade 1
MW-700-12		32	Grade 2

# Traditional Vee Blocks & Clamps 230 Series

## At a Glance

- Standard: BS5535 Grade B
- For setup and alignment of small work pieces for drilling or machining

## 230 General Workshop Grade

- Manufactured from close grained cast iron
- Supplied in matched and numbered pairs
- One steel clamp and screw supplied per pair

## 231 Precision Vee Blocks

- Manufactured to BS3731 grade B
- Manufactured from case hardened and ground mild steel
- Supplied in matched pairs only
- Two malleable iron clamps with steel screws supplied with each pair of blocks
- Supplied in box

## Availability & Compliance

- Available in Australia & New Zealand
-  Indent Only, not stocked, supplied to order



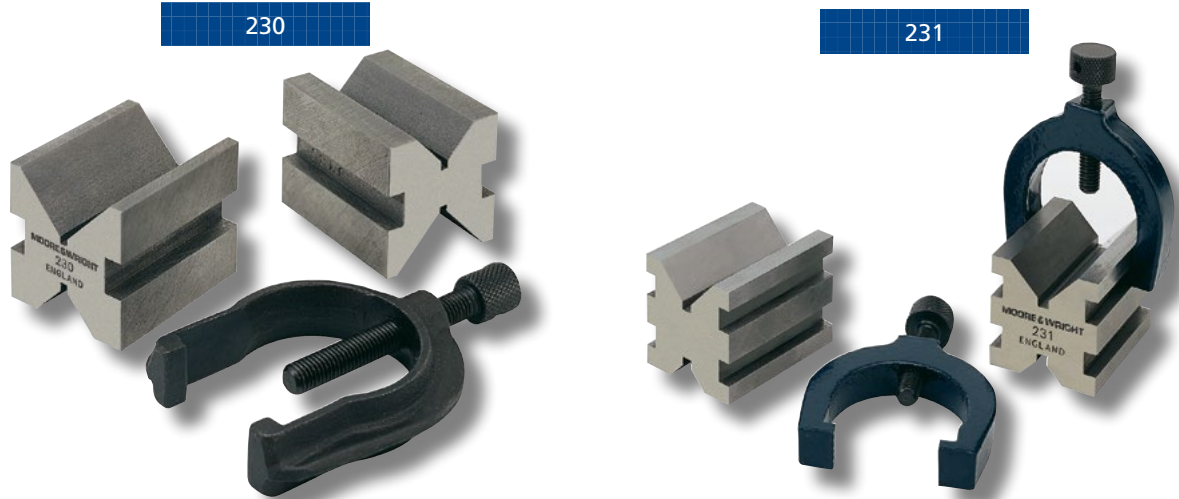

**Traditional Vee Blocks & Clamps**

Code No	Accuracy		Range		Width		Length		Height	
	(mm)	(inch)	(mm)	(inch)	(mm)	(inch)	(mm)	(inch)	(mm)	(inch)
MW-230	0.05	0.020	40	1 1/2	40	1 1/2	50	2	50	40
MW-231 (MATCHED PAIR)	 0.01	0.004	32	1	32	1 1/4	42	1 5/8	42	32

**Vee Blocks - Spare Clamps**

Code No	Description
MW-23001	Spare Clamp and Screw for 230
MW-23101	Spare Clamp and Screw for 231

# Carbide Tipped Scriber SCT Series

## At a Glance

- For marking out of materials to enable machining, cutting or drilling

## Features

- Pearl-chrome finish
- Robust design
- Pocket clip
- MW-SCT001XR has handy magnetic end



SCT001XR



SCT002R

## Carbide Tipped Scriber

Code No	Description
MW-SCT001XR	Scriber - Carbide Tipped - Supplied with spare tip
MW-SCT002R	Retail Pack, fixed carbide tipped scriber



## Availability & Compliance

- Available in Australia & New Zealand



# Telescopic Gauge Set 315 Series

## At a Glance

- For quick and easy measurement of tubes and bores



MW-315-01

## Features

- Spring loaded plunger that expands in the bore or groove
- Satin-chromed body
- With auto extension and direct locking
- Measuring faces are hardened and micro-lapped
- Range 8 - 12.7mm  
12.7 - 19mm  
19 - 32mm  
32 - 54mm  
54 - 90mm  
90 - 150mm

### Telescopic Gauge Set- 315 Series

Code No	Range (mm)	Pack Quantity
MW-315-01	8-150	6-pieces

## Availability & Compliance

- Available in Australia & New Zealand

# Index



## CALIPERS

Workshop Vernier - 100 Series	4
Workshop Vernier - 105 Series	5
Precision Vernier - 110 Series	6
Thumb Lock Vernier - 115 Series	7
Large Workshop Vernier - 150 Series	8
Mono Block Large Workshop Vernier - 152 Series	9
Long Jaw Vernier - 155 Series	10
Dial - 140 Series	11
Workshop Digital - 110-DBL Series	12
Fractional Reading Digital - 110-DFC Series	13
Digital Absolute - 110-DABS Series	14
IP54 Water Resistant 110-WR Series	15
Digital Vernier - 110-WIP Series	16
Digital - Interchangeable Anvils - 127-DABS Series	17
Digital External Groove IP54 - 120-DABS Series	18
Digital Long Jaw - 110-DLJ Series	19
Large Digital Workshop - 150 Series	20
Heavy Duty Digital Workshop - 160-D Series	21
Vernier - 170 Series	22

## DEPTH GAUGES

Digital - Without Hook - 170-DB Series	23
Dial - 172 Series	24
Digital - 172 Series	25
Double Column - 195 Series	26

## HEIGHT GAUGES

Digital - 193 Series	27
Double Column Digital - 195 Series	28

## MICROMETERS

Traditional External - 1965 Series	29
Traditional External - 1966 Series	30
External - 200 Series	31
Workshop Outside - 200-BL Series	32
Workshop External Set - 215 Series	33
Digital External - 201 Series	34
Digital External IP65 - 203 Series	35
Large External - 210 Series	36



Interchangeable Anvils - 217 Series	37
Large Adjustable External - 220 Series	38
Large Adjustable External Digital - 220 Series	39
Workshop Blade - 275 Series	40
Tube - 255 Series	41
Tube Digital - 255 Series	42
Point - 270 Series	43
Caliper Type Inside - 280 Series	44
Digital Inside - 280-DDL Series	45
Tubular Internal - 300 Series	46
Traditional Internal - 900 Series	47
Digital Internal - 300-DABI Series	48
Traditional Depth - 890 Series	49
Digital Depth - 305-DDL Series	50
Micrometer Stand	51

**BORE GAUGES**

Dial Sets - 316 Series	52
Digital Sets - 316 Series	53

**INDICATORS**

Dial Test - 420 Series	54
Dial Test Accessories	55
Dial - 400 Series	57
Dial - 401 Series	58
Digital - 405 Series	59
Digital - 415 Series	60
Digital Absolute - 430-DABS Series	61

**INDICATOR STANDS**

Magnetic Indicator Stand - 470 Series	62
Magnetic Indicator Stand - 475 Series	63
Flexible Magnetic Base - 496 Series	64
Hydraulic Magnetic Base - 485 Series	65
Articulating Magnetic Fine Adjustment - 477 Series	66
Magnetic Base and Indicator Set	67
Magnetic Base and Digital Indicator Set	68

**HAND TOOLS**

Precision Combination Sets	69
Workshop Combination Set - 521 Series	70

Universal Bevel Protractor	71
Dial Bevel Protractor	72
Digital Universal Bevel Protractor	73
Digital Protractor - 505 Series	74
Digital Angle Rule	75
Protractor - 946 Series	76
Traditional Depth Gauge - 0-150mm	77
Traditional Engineers' Square - Grade B	78
Precision Engineers' Bevelled Edge Square	80
Sliding 'T' Squares	81
Traditional Inside Calipers Firm Joint	83
Dividers & Inside / Outside Calipers Spring Joint	83
Traditional Outside Calipers Firm Joint	83
Traditional Hermaphrodite Calipers	84
Traditional Surface Gauges	85
Traditional Feeler Gauge Set - Precision Range	87
Traditional Screw Cutting Gauges	88
Traditional Screw Pitch Gauges - 800 Series	91
Traditional Standard Wire Gauges	92
Traditional Drill Gauges	92

**LEVELLING**

Traditional Engineers' Level	93
Engineers' Level - 550 Series	94
Mini Level - ELT Series	95
Digital Mini-Mag - 570 Series	96
IP65 Magnetic Digital - 575 Series	97
Digital Level - 580 Series	98

**WORKSHOP TOOLS**

Traditional Angle Plates	99
Steel Gauge Blocks - 700 Series	101
Traditional Vee Blocks & Clamps	103
Carbide Tipped Scribers	104
Telescopic Gauge Set- 315 Series	105

# Code Index



CALIPERS			
MW-100-15B	4	MW-110-20DFC	13
MW-100-20B	4	MW-110-30DFC	13
MW-100-30B	4	MW-110-15DABS	14
MW-100-15BI	4	MW-110-20DABS	14
MW-100-20BI	4	MW-110-30DABS	14
MW-100-30BI	4	MW-Y100/700USB	14
MW-105-20	5	MW-110-15WR	15
MW-105-30	5	MW-110-20WR	15
MW-105-20I	5	MW-110-30WR	15
MW-105-30I	5	MW-110-15WIP	16
MW-110-15	6	MW-110-20WIP	16
MW-110-20	6	MW-110-30WIP	16
MW-110-30	6	MW-127-30DABS	17
MW-110-15I	6	MW-120-20DABS	18
MW-110-20I	6	MW-110-15DLJ	19
MW-110-30I	6	MW-150-50DDL	20
MW-115-15I	7	MW-150-60DDL	20
MW-115-20I	7	MW-150-75DDL	20
MW-150-52	8	MW-160-20D	21
MW-150-62	8	MW-160-30D	21
MW-150-72	8	MW-170-15	22
MW-150-82	8	MW-170-20	22
MW-152-55	9	MW-170-30	22
MW-152-65	9	MW-170-50BI	22
MW-152-75	9		
MW-155-32	10	DEPTH GAUGES	
MW-155-52	10	MW-170-15DB	23
MW-155-62	10	MW-170-20DB	23
MW-155-72	10	MW-170-30DB	23
MW-146-15	11	MW-170-30DB/100	23
MW-146-20	11	MW-172-01	24
MW-146-30	11	MW-172-01D	25
MW-146-15I	11	MW-195-30	26
MW-110-15DBL	12	MW-195-50	26
MW-110-20DBL	12	HEIGHT GAUGES	
MW-110-30DBL	12	MW-193-30DDL	27
MW-110-15DFC	13	MW-193-60DDL	27
		MW-195-30DDL	28



MW-195-60DDL	28	MW-215-04BI	33	MW-220-02	38
<b>MICROMETERS</b>					
MW-1965M	29	MW-201-01DAB	34	MW-220-03	38
MW-1965	29	MW-201-02DAB	34	MW-220-04	38
MW-1966M50	30	MW-201-03DAB	34	MW-220-05	38
MW-19662	30	MW-201-04DAB	34	MW-220-06	38
MW-1966M75	30	MW-Y100/700USB	34	MW-220-07	38
MW-19663	30	MW-203-01DABI	35	MW-220-08	38
MW-1966M100	30	MW-203-02DABI	35	MW-220-09	38
MW-19664	30	MW-203-03DABI	35	MW-220-01DDL	39
MW-1966M125	30	MW-203-04DABI	35	MW-220-02DDL	39
MW-19665	30	MW-203-05DABI	35	MW-220-03DDL	39
MW-1966M150	30	MW-203-06DABI	35	MW-220-04DDL	39
MW-19666	30	MW-203-07DABI	35	MW-220-05DDL	39
MW-1966MB50	30	MW-203-08DABI	35	MW-220-06DDL	39
MW-1966MB75	30	MW-203-09DABI	35	MW-220-07DDL	39
MW-1966MB100	30	MW-203-10DABI	35	MW-275-01	40
MW-1966MB125	30	MW-203-11DABI	35	MW-275-02	40
MW-1966MB150	30	MW-203-12DABI	35	MW-275-03	40
MW-200-01	31	MW-203-SPC-BT	35	MW-275-04	40
MW-200-02	31	MW-210-01	36	MW-255-01	41
MW-200-03	31	MW-210-02	36	MW-255-01DDL	42
MW-200-04	31	MW-210-03	36	MW-270-01	43
MW-200-01I	31	MW-210-04	36	MW-270-02	43
MW-200-02I	31	MW-210-05	36	MW-270-03	43
MW-200-03I	31	MW-210-06	36	MW-270-04	43
MW-200-04I	31	MW-210-07	36	MW-270-05	43
MW-200-01BL	32	MW-210-08	36	MW-270-06	43
MW-200-02BL	32	MW-217-01	37	MW-270-07	43
MW-200-03BL	32	MW-217-02	37	MW-270-08	43
MW-200-04BL	32	MW-217-03	37	MW-280-01	44
MW-215-01BL	33	MW-217-04	37	MW-280-02	44
MW-215-02BL	33	MW-217-05	37	MW-280-03	44
MW-215-03BL	33	MW-217-01I	37	MW-280-04	44
MW-215-04BL	33	MW-217-02I	37	MW-280-05	44
MW-215-01BI	33	MW-217-03I	37	MW-280-06	44
MW-215-02BI	33	MW-217-04I	37	MW-280-07	44
MW-215-03BI	33	MW-217-05I	37	MW-280-08	44
		MW-220-01	38	MW-280-01DDL	45

MW-280-02DDL	45
MW-280-03DDL	45
MW-280-04DDL	45
MW-280-05DDL	45
MW-280-06DDL	45
MW-300-01	46
MW-300-02	46
MW-300-04	46
MW-901M	47
MW-902M	47
MW-903M	47
MW-901	47
MW-902	47
MW-903	47
MW-300-05DABI	48
MW-300-06DABI	48
MW-300-07DABI	48
MW-890M	49
MW-890	49
MW-891M75	49
MW-8913	49
MW-891M150	49
MW-8916	49
MW-891M300	49
MW-89112	49
MW-892M75	49
MW-8923	49
MW-892M150	49
MW-8926	49
MW-892M300	49
MW-89212	49
MW-305-00DDL	50
MW-305-01DDL	50
MW-305-02DDL	50
MW-305-03DDL	50
MW-305-04DDL	50
MW-305-05DDL	50
MW-279-01A	51

### BORE GAUGES

MW-316-01	52
MW-316-02	52
MW-316-03	52
MW-316-04	52
MW-316-05	52
MW-316-06	52
MW-316-12D	53

### INDICATORS

MW-420-03	54
MW-420-04	54
MW-421-02	54
MW-422-01	54
MW-420-03I	54
MW-420-04I	54
MW-Z40010	55
MW-Z40016	55
MW-Z40012	55
MW-Z40018	55
MW-Z40013	55
MW-Z40020	55
MW-Z40014	55
MW-Z40022	55
MW-400-01	57
MW-400-02	57
MW-400-03	57
MW-400-04	57
MW-400-05	57
MW-400-06	57
MW-400-06B	57
MW-400-08	57
MW-400-09	57
MW-401-01	58
MW-401-02	58
MW-401-05	58
MW-405-04DB	59
MW-405-06DB	59
MW-415-01	60

MW-415-02	60
MW-415-03	60
MW-415-04	60
MW-430-01DABS	61
MW-430-02DABS	61
MW-430-03DABS	61
MW-Y100/700USB	61

### INDICATOR STANDS

MW-470-01	62
MW-475-01	63
MW-496-01	64
MW-485-01	65
MW-477-01	66
MW-475-SET1	67
MW-475-SET2	68

### HAND TOOLS

MW-CSM300	69
MW-CSME12	69
MW-CSRM300	69
MW-CSRM600	69
MW-CSRME12	69
MW-CSRME24	69
MW-521-01	70
MW-500-01	71
MW-510-01	72
MW-500-01D	73
MW-505-01	74
MW-505-02	74
MW-505-03	74
MW-506-01	75
MW-506-02	75
MW-946-01	76
MW-946-02	76
MW-946-03	76
MW-946-04	76
MW-43M	77
MW-44M	77
MW-43	77



MW-44	77	MW-331/8	83	MW-1067M	92
MW-400/3	78	MW-331/12	83	MW-1066M	92
MW-400/4	78	MW-331/18	83	<b>LEVELLING</b>	
MW-400/6	78	MW-331/24	83	MW-ELS	93
MW-400/9	78	MW-341	84	MW-ELM	93
MW-400/12	78	MW-336/6	84	MW-550-03	94
MW-910-01	80	MW-56	84	MW-ELT001XR	95
MW-910-02	80	MW-E101B	85	MW-570-01	96
MW-910-03	80	MW-E102B	85	MW-570-01W	96
MW-910-04	80	MW-911-10-B	87	MW-575-01DIP	97
MW-910-05	80	MW-1246-10-A	87	MW-575-01WIP	97
MW-910-06	80	MW-12412-10-A	87	MW-580-01	98
MW-DS71041	81	MW-12-26-A	87	MW-580-02	98
MW-DS71051	81	MW-911M-10-B	87	MW-580-03	98
MW-DS71044	81	MW-391M-11-A	87	<b>WORKSHOP TOOLS</b>	
MW-DS71056	81	MW-387M-13-A	87	MW-E200	99
MW-330/6	83	MW-388M-13-B	87	MW-E201	99
MW-330/8	83	MW-393M-20-A	87	MW-E202	99
MW-330/12	83	MW-390M-20-B	87	MW-E204	99
MW-50/3	83	MW-395M-20-A	87	MW-E301	99
MW-51/3	83	MW-399M-20-A	87	MW-E302	99
MW-52/3	83	MW-390M-32-B	87	MW-E304	99
MW-50/4	83	MW-200	88	MW-700-02	101
MW-51/4	83	MW-204M	89	MW-700-03	101
MW-52/4	83	MW-206M	89	MW-700-05	101
MW-50/6	83	MW-204MA	89	MW-700-06	101
MW-51/6	83	MW-206MA	89	MW-700-08	101
MW-52/6	83	MW-204	89	MW-700-09	101
MW-50/8	83	MW-206	89	MW-700-11	101
MW-51/8	83	MW-204A	89	MW-700-12	101
MW-52/8	83	MW-206A	89	MW-230	103
MW-50/10	83	MW-804	91	MW-231	103
MW-51/10	83	MW-809	91	MW-23001	103
MW-52/10	83	MW-799	91	MW-23101	103
MW-50/12	83	MW-800	91	MW-SCT001XR	104
MW-51/12	83	MW-806	91	MW-SCT002R	104
MW-52/12	83	MW-1053M	92	MW-315-01	105
MW-331/6	83	MW-1052	92		



Spear & Jackson Australia PTY LTD

PO BOX 4400

Dandenong South, Victoria Australia 3175

Tel: 1300 731 818

Email: [sales@spearandjackson.com.au](mailto:sales@spearandjackson.com.au)